

Instructions for Use

For Automatic Swing Doors with Drive:

TORMAX iMotion® 1301 Swing Door Drive

TORMAX iMotion® 1301.S Swing Door Drive

TORMAX iMotion® 1302.KI Swing Door Drive

TORMAX iMotion® 1401 Swing Door Drive



Please follow the safety instructions in chapter 2!

Table of Contents

| | | |
|----------|--|-----------|
| 1 | General Information | 3 |
| 1.1 | Target Groups | 3 |
| 1.2 | Storage and Forwarding of the Manual | 3 |
| 1.3 | Area of Application | 3 |
| 1.4 | Explanation of the Symbols | 4 |
| 1.5 | Technical Data | 4 |
| 2 | Safety | 5 |
| 2.1 | Responsibilities | 5 |
| 2.2 | Use for the Purpose Intended | 5 |
| 2.3 | Improper use | 6 |
| 2.4 | Pre-conditions for the Operation of the System | 6 |
| 2.5 | Hazards and Risks | 7 |
| 2.6 | Checks | 7 |
| 2.7 | Decommissioning the System in the Event of a Fault | 8 |
| 2.8 | Disposal | 8 |
| 3 | System Overview | 9 |
| 4 | System Function | 12 |
| 4.1 | Automatic Door Operation with Sensors | 12 |
| 4.2 | Door Leaf Protection | 12 |
| 4.3 | System with Full-Energy Mode | 12 |
| 4.4 | Systems with Low-Energy Mode | 12 |
| 4.5 | Semi-automatic Operation with "Push-and-Go" | 12 |
| 4.6 | Traffic Control | 12 |
| 4.7 | Automatic System Monitoring | 13 |
| 4.8 | Electric Lock | 13 |
| 4.9 | Operation in the Event of a Power Failure | 13 |
| 4.10 | Operating Modes | 14 |
| 5 | Operation | 15 |
| 5.1 | Commissioning | 15 |
| 5.2 | Operation with the TORMAX User Interface | 15 |
| 5.3 | Operation with an Operating Mode Switch | 16 |
| 5.4 | Operation on Power Failure | 16 |
| 5.5 | Resetting the Panic Fitting | 16 |
| 6 | Procedure in the Event of a Fault | 17 |
| 7 | Maintenance | 18 |
| 7.1 | Cleaning | 18 |
| 7.2 | Functional Checks | 18 |
| 7.3 | Maintenance and Testing | 18 |
| 8 | Appendix | 19 |
| 8.1 | Fault Table | 19 |
| 8.2 | Check-List for Functional Checks | 20 |
| | Declaration of Conformity | 22 |

First edition: 2.12.11, update: 2.12, 5.21, 8.23

We reserve the right to make technical changes.

1 General Information

1.1 Target Groups

- Operator of the automatic swing door. The operator is the person responsible for the operation and maintenance of the system.
- Persons instructed by the operator to carry out certain duties, for example the servicing and maintenance of the automatic swing door.

1.2 Storage and Forwarding of the Manual

- Store the instructions for use in the vicinity of the automatic door system.
- If the manual has become illegible due to constant usage, reorder the instructions. For download and print out see also: www.tormax.com
- When the door system is transferred or resold to a third party, pass the following documents to the new owner:
 - This instructions for use
 - Documentation concerning modification and repair work
 - Proof of the regular examinations → System test book T-879

1.3 Area of Application

Product name, door system: Automatic swing door

Product name, door drive: **TORMAX iMotion® 1301 Swing Door Drive**
TORMAX iMotion® 1301.S Swing Door Drive
TORMAX iMotion® 1302.KI Swing Door Drive
TORMAX iMotion® 1401 Swing Door Drive

The door drives are defined in more detail by a 4-figure number:

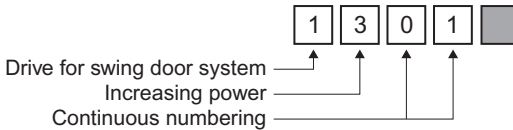

■ .S = Drive with increased power
 ■ .KI= Drive integrated in lintel without linkage

Door system identification plate (example):
 located on the side panel of the drive.



The identification plate with the serial number is placed in the control box (1401) or on the drive itself under the casing (1301, 1301.S, 1302.KI).

| | | | | | |
|---------|--|--|--|--------------------------|-------------|
| | | TORMAX Unterweg 14 CH-8180 Bulach-Zürich A Division of LANGERT Group AG | | | |
| Model: | | | | | |
| | | | | | |
| Un: | | | | | |
| Pmax.: | | Imax.: | | Pedestrian Door Operator | |
| Pmin.: | | Imin.: | | Manufactured: MM/YYYY | |
| Leaves: | | | | | |
| | | | | | Serial No.: |

1.4 Explanation of the Symbols



Warning (signal word)

Source of hazard (designates a possibly hazardous situation)

Possible consequences of non-observance

- Measures for averting danger.

Text which is highlighted in grey MUST be observed to ensure that the system operates perfectly. Failure to observe these sections can cause damage to equipment.

- ⊙ Functions marked with this symbol are the factory setting. However, they can be reprogrammed by a specialist.
- ◆ Optional components which are not present in all systems.

1.5 Technical Data

| | | | |
|-------------------------------------|--|---|----------------------|
| Drive type | Electromechanical swing door operator with AC permanent magnet synchronous motor | | |
| Control system | Control unit MCU32 | | |
| Mains connection | 1 x 230 V AC, 10 – 16 A 1 x 115 V AC, 15 – 20 A, 50 – 60 Hz | | |
| Power consumption | iMotion 1301 | 5 ... 250 W | |
| | iMotion 1301.S | 12 ... 330 W | |
| | iMotion 1302.KI | 6 ... 205 W | |
| | iMotion 1401 | 6 ... 250 W | |
| Sensor supply | iMotion 1301, 1302.KI | 24 V DC +0,5/-1,5V, max. 18 W / 0,75 A, in battery operation min. 16,5V | |
| | iMotion 1301.S, 1401 | 24 V DC +0,5/-1,5V, max. 36 W / 1,5 A, in battery operation min. 16,5V | |
| Protective class, drive | iMotion 1301, 1301.S, 1302.KI | IP 20 | |
| | iMotion 1401 | IP 68 | |
| Protective class, control box | iMotion 1401 | IP 55 | |
| Ambient temperature | -20 °C to +50 °C | | |
| Fuse | iMotion 1301, 1302.KI | 8 AT (TÜV) / 5 AT (UL) | |
| | iMotion 1301.S, 1401 | 8 AT | |
| Weight drive | iMotion 1301, 1301.S | 14,5 kg | |
| | iMotion 1302.KI | 13,9 kg | |
| | iMotion 1401 | 39 kg | Control unit: 3,9 kg |
| Noise emission level | < 70 db(A) | | |
| Electromagnetic compatibility (EMV) | IEC 61000-6-2, IEC 61000-6-3 | | |
| Service life | Tested to 1'000'000 cycles | | |

2 Safety



Warning

Important safety instructions

It is important to comply with these Instructions to ensure the safety of persons.
These Instructions must be kept in a safe place.

2.1 Responsibilities

| | |
|---------------------------------------|---|
| Installation of the system: | A qualified person from a TORMAX sales partner |
| For instructing the operator: | A qualified person from a TORMAX sales partner |
| For operating the system: | The operator or a person instructed by the operator |
| For maintenance and function control: | The operator or a person instructed by the operator |
| For annual testing and approval: | A qualified person authorised by the manufacturer |

Specialists are persons who have adequate knowledge in the field of power-operated doors as a result of their specialist training and experience and who are so familiar with the relevant health and safety regulations, guide-lines and generally recognised codes of practice that they are able to assess the condition of power-operated doors with regard to the safety of their operation.

Maintenance of electrical parts must be carried out by a trained electrician.

2.2 Use for the Purpose Intended

The product including the associated components is designed for the automation of swing doors for pedestrian passageways. The drive may only be installed inside or on the inside of buildings in a dry environment.

- Installation, maintenance and repair work as well as commissioning of the drive may only be carried out by a qualified person. This qualified person is also responsible for the safety of users or third parties.
- The swing door drive may only be operated by properly trained persons who must also follow the Instructions for Use. This instructed person is also responsible for the safety of users or third parties.
- The door system may be used by persons with impaired physical, mental or sensory capabilities provided that they are either under the supervision of the person responsible for their safety that the latter has instructed them on the safe use of the system and its potential risks.
- Children must be supervised to ensure that they do not play close to the system and do not operate any available operating controls..

2.3 Improper use

The manufacturer will not accept any liability whatsoever for loss or damage caused by improper use, failure to comply with the maintenance specification (see chapter 7) or unauthorised modification of the system.

- Any conversion of the system (e.g. other user groups) is not permitted without a new risk assessment (by a qualified person) and the measures derived from it.
- Structural alterations in the danger area around the door system are prohibited without a new risk assessment (by a qualified person) and the measures derived from it.
- Modifications to the door system (e.g. different, heavier door leaves, different operating equipment or sensor systems) may only be undertaken by a qualified person who complies with the technical limit values.
- Safety facilities (e.g. sensor technology, manual unlocking) must not be removed or disabled.

Other improper uses (examples)

- Automatic doors with leaves moving vertically or in an inclined plane.
- Automatic doors and gates located in transport equipment (e.g. motor vehicles or lifts)
- Door systems incorporating a wicket door must not be automated.
- The drive must not be used as a drive for a wicket door.
- Use in abrasive and corrosive environments or in areas subject to the danger of explosions.

2.4 Pre-conditions for the Operation of the System

The door system was designed, installed and checked for functionality and safety by specialists prior to hand-over to the operator. The company responsible for the system's installation instructed the operator on the system's use and maintenance as well dangers associated with the system operation. The operator has confirmed this by his signature in the system test book T-879.

The provisions imposed by law, health and safety and occupational health regulations for the avoidance of accidents and the protection of the environment which are generally applicable in the country in which the system is operated supplement the instructions for use.

- The staff responsible (see chapter 2.1) must have read and understood these Instructions before commissioning or using the door system.
- Only use the system when it is in perfect working order. The operating conditions, inspection and maintenance intervals stipulated by the manufacturer must be observed (chapter 7).
- Arrange to have any faults rectified immediately by a specialist.

2.5 Hazards and Risks

Depending on the system design and equipment, there is a residual risk of crushing (1), shearing (2) and collision (3) with limited force in the movement area of the door leaf.

iMotion 1301, 1301.S

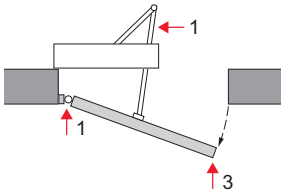

iMotion 1302.KI

Open

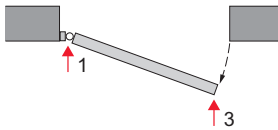

iMotion 1401

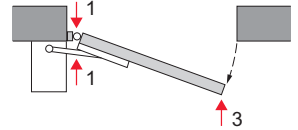

Close

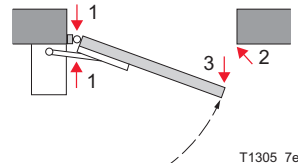
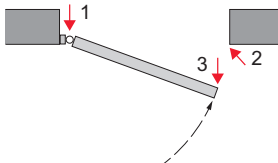
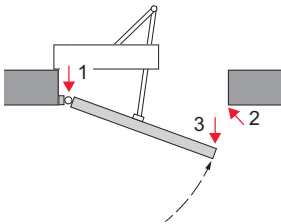

T1305_7e



Warning

Danger through moving parts:

- in the area of all closing edges (especially hinge)
- in the region of the linkage lever
- when objects such as, for example, display shelves are erected in the direct proximity of the moving part of the door leaf.



Warning

Hazards can arise due to deliberate damage, incorrect installation, defective sensors or sensors which are longer properly adjusted, sharp edges, incorrectly mounted and defective casing or missing covers.

Danger for body and life, danger of injury

- Have system repaired by a qualified person

2.6 Checks

The regular checks and examinations set out in chapter 7 must be carried out as instructed by the manufacturer.

2.7 Decommissioning the System in the Event of a Fault

If there is a fault the automatic swing door may only be taken out of service by a skilled person, the operator or a person who is instructed to do so by the operator. This must be done on all occasions on which the safety of persons could be compromised.

- Disconnect the door system from the power supply. All the poles are disconnected using a 3-pole IEC-plug or another all-pole disconnection device (e.g. in the fuse box).
- If another power source (e.g. battery ♦) is available, it must be disconnected from the system by a specialist.
- Open the door manually and fix it open if it is installed in an escape route.

See chapter 6 and 8 for rectification of faults.

2.8 Disposal

This system must be properly dismantled at the end of its working life. Its disposal must comply with national regulations. We recommend that you contact a skilled person disposal company.



Warning

Electric voltage

Risk of injury by electric shock

- Disconnect the mains power supply to the installation before dismantling.



Warning

Aggressive acids

Risk of injury if you dismantle the battery module.

- Dispose of batteries properly.



Warning

Flying around parts

The tensioned spring represents a hazard when dismantling the drive.

- The drives may only be dismantled and prepared for proper disposal by a competent person.



Warning

Broken glass

Risk of injury when dismantling the door leaves.

- Take care when transporting the door leaves.

3 System Overview

TORMAX iMotion 1301, 1301.S

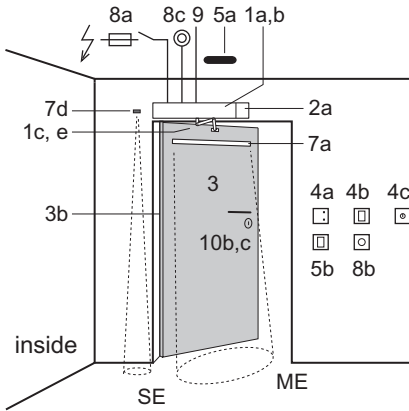

TORMAX iMotion 1302.KI

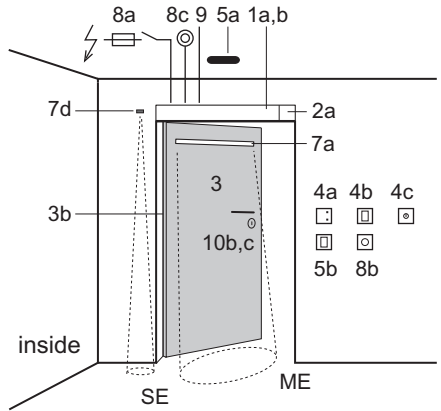

TORMAX iMotion 1401

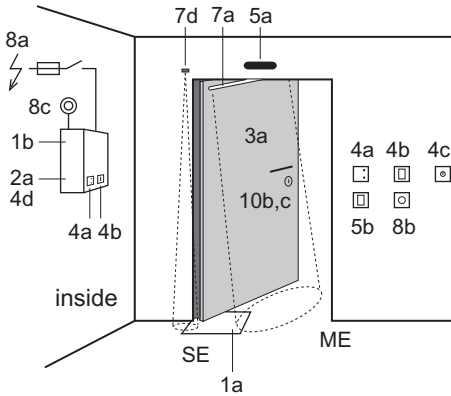

**TORMAX iMotion 1301, 1301.S
1302.KI, 1401**

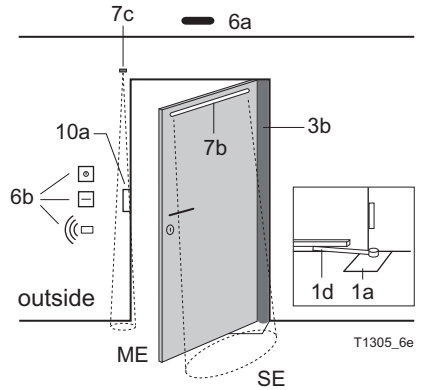

T1305_6e

| | | |
|-----------|----------------------------|--|
| 1 | Drive | a) Motor unit b) MCU32 control system with monitoring system, power limitation and permanent diagnosis. <input type="checkbox"/> Controlled closing function of the door in power-off condition <input type="checkbox"/> Controlled opening function in power-off condition c) Linkage/sliding lever (1301, 1301.S) d) <input type="checkbox"/> Pull arm (1401) e) <input type="checkbox"/> Panic fitting (not approved for drive type 1302.KI-UL) |
| 2 | Drive accessories | a) <input type="checkbox"/> Emergency power supply via the battery unit <input type="checkbox"/> Mechanical door coordinator for double-leaf doors <input type="checkbox"/> ... |
| 3 | Door leaves | a) Swing leaf with main closing edge (ME) and secondary closing edge (SE) * b) <input type="checkbox"/> Finger protection, safeguarding the secondary closing edge * |
| 4 | Operating controls | a) <input type="checkbox"/> iMotion user interface with 6 operating modes and fault display b) <input type="checkbox"/> Operating mode switch with 3 positions c) <input type="checkbox"/> Lock for the user interface d) <input type="checkbox"/> Remote control of operating modes |
| 5 | Internal activators | a) With automatic activation <input type="checkbox"/> Radar with/without direction recognition * <input type="checkbox"/> IR motion detector * <input type="checkbox"/> Contact mat * b) With manual activation <input type="checkbox"/> Push button * <input type="checkbox"/> Contact-free button * <input type="checkbox"/> ... |
| 6 | External activators | a) With automatic activation <input type="checkbox"/> Radar with/without direction recognition * <input type="checkbox"/> IR motion detector * <input type="checkbox"/> Contact mat * <input type="checkbox"/> ... b) With manual activation <input type="checkbox"/> Key switch <input type="checkbox"/> Card reader * <input type="checkbox"/> Remote control * <input type="checkbox"/> ... |
| 7 | Safety sensors | a) <input type="checkbox"/> Presence sensor * safeguarding the swing area when closing b) <input type="checkbox"/> Presence sensor * safeguarding the swing area when opening c) <input type="checkbox"/> Presence sensor * safeguarding the opposing closing edge (OE) d) <input type="checkbox"/> Presence sensor * safeguarding secondary closing edge (SE) <input type="checkbox"/> ... |
| 8 | Emergency systems | a) <input type="checkbox"/> Power switch/fuse * b) <input type="checkbox"/> Emergency-off switch * c) <input type="checkbox"/> External fire alarm system * |
| 9 | Output message | <input type="checkbox"/> Bell/gong * <input type="checkbox"/> Light * <input type="checkbox"/> Door status |
| 10 | Lock | a) <input type="checkbox"/> Electrical door opener * b) <input type="checkbox"/> Door handle * c) <input type="checkbox"/> Mechanical door lock * |

Depending on the system's equipment

* Provided by the installation company.

The company installing the system must select and install suitable components in accordance with the product standard EN16005.

Block Diagram

All work on the mains power supply cable and the system's cabling must only be undertaken by an authorised and properly trained person who must refer to all necessary documents.

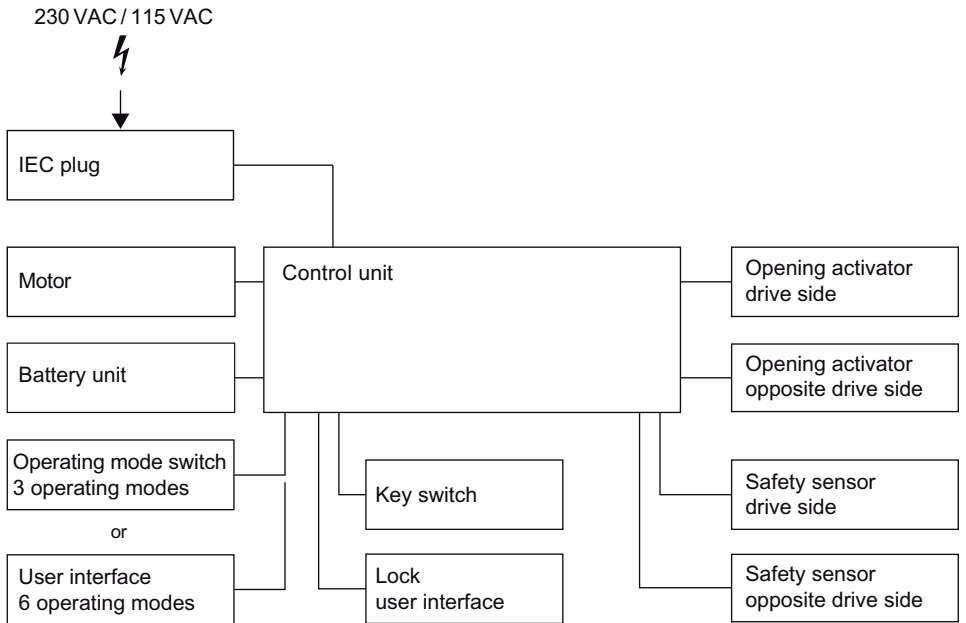

T1305_14e

4 System Function

The operator of the door system is responsible for ensuring that the automatic swing door is freely accessible at all times. The operator must particularly ensure that the swing area of the door leaves is not obstructed by any objects.

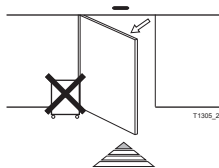

4.1 Automatic Door Operation with Sensors

When operating automatically (AUTOMATIC operating mode) the door is automatically opened from both sides by sensors when a person approaches. A key switch ◆ or card reader ◆ normally allows access from outside when the door is in operating mode EXIT or OFF. The door unlocks, opens and closes again as soon as no further sensors are activated after a hold-open time which is set separately.

Double-leaf doors open at the same time or, in the case of overlapping door leaves, in sequence. Closing must be in the correct closing sequence and, for reasons of safety, one after the other.

4.2 Door Leaf Protection

The safety devices are selected and installed by the installation company in line with general and country-specific standards, guide-lines and requirements.

4.3 System with Full-Energy Mode

The door leaves are equipped with safety sensors on the leaves. The safety sensors prevent a person in the operating radius of the leaf from being hit by the leaf. If one of the safety sensors should fail, the system switches to safety mode. The door can still be opened but only manually. In the case of low risk systems, the system switches to emergency mode. The door leaf still moves but only slowly and in Low-Energy mode. If the safety device fails in the closing direction, the door remains open for 30 seconds.

4.4 Systems with Low-Energy Mode

Hazards due to impact and crushing are minimised by restrictions on speed and force. Thus the system provides a high degree of safety. The system offers maximum ease of use and safety if it is equipped with additional safety sensors.

4.5 Semi-automatic Operation with “Push-and-Go”

Instead of having sensors the door can be manually pushed open. After being detected by the control system, the door opens automatically and closes again.

4.6 Traffic Control

Movement through the door can be allowed in only one direction if desired (operating mode EXIT) or completely blocked (operating mode OFF). If there is a high level of pedestrian traffic or if the door is to be used by infirm or frail persons, the door can be switched to operate in operating mode AUTOMAT 2 with a longer hold-open time. Double-leaf door systems can also be operated as single leaf doors by means of the single leaf operation switch. In this case both doors can only be opened by means of the key switch or the “passageway for beds” switch.

4.7 Automatic System Monitoring

The control system monitors the safety sensors by a cycle of active tests. The control system also conducts continuous internal system tests. If a safety-related component should fail, the system automatically switches into a safe condition. At the same time the fault number is displayed on the user interface. You can find further information on this subject in chapter 6.

4.8 Electric Lock ◆

The system can be locked in the closed position by means of an electric lock ◆.

4.9 Operation in the Event of a Power Failure

Depending on the equipment installed, the following functions are possible:

- Controlled closing using the integral spring. The door can be opened manually by means of the door handle (unlocking).
 - The door then closes again in a controlled manner using the integral spring.
- Controlled opening using the integral spring. The door remains open.
- Continued operation for a certain period in the current operating mode by means of a battery unit ◆.
- Unlocking and opening of the door from outside by means of a key switch and the battery unit ◆.

The closing sequence is maintained in double-leaf door systems by the use of a mechanical door coordinator.

4.10 Operating Modes

The automatic door system can be operated with the TORMAX user interface ◆ (6 operating modes and status display) or with an operating mode switch ◆ (3 operating modes).

Operating Mode OFF

The internal and external sensors are disregarded. The door is mechanically held in the closed position and locked using an electric lock ◆. Access is only possible using the key switch or if the door is manually unlocked using a key or the door handle is used to open the door manually.

⊙ The door can still be used for 5 seconds after selecting operating mode OFF. The door then locks at the end of this period as soon as it is closed. The transition is signalled on the user interface by the flashing display of operating mode OFF.

Operating Mode AUTOMATIC 1

The operating mode AUTOMATIC 1 is normally used during the day. The door opens automatically through the inside and outside sensors. The door can behave differently depending on the settings programmed during commissioning:

“Push-and-Go”

If the door is manually pushed in the opening direction, it reacts as if to a command to open: it opens automatically, waits for the hold-open time and then closes.

Systems with an Electric Door Lock ◆

The lock unlocks on every valid opening impulse. The door lock must be manually unlocked with the door handle before it is possible to open the door with the “Push- and-Go” system. In this operating mode the door lock can also be permanently unlocked depending on the setting programmed at the time of commissioning.

Operating Mode AUTOMATIC 2

Corresponds to operating mode AUTOMATIC 1 but a different motional sequence can be set during commissioning (e.g. a slower opening movement, different open positions and a longer hold-open time).

Operating Mode EXIT

Operating mode EXIT is normally used for the period before the shop or office closes. The door will only open automatically when activated by the internal sensor. When the door opens the external sensor is also monitored for safety reasons. The open position is determined by the preceding selection of the operating mode AUTOMATIC 1 or AUTOMATIC 2. Additionally the door can be locked automatically by the door lock ◆. The door lock can be permanently unlocked in this operating mode in case of need.

Operating Mode OPEN

The door opens and remains open. The open position is determined by the preceding selection of the operating mode AUTOMATIC 1 or AUTOMATIC 2. The door opens again on receiving the next open impulse or when changing the operating mode to OFF and back again to OPEN.

P Operating Mode Manual Operation

The door leaf can be freely moved. This operating mode can be used for cleaning the door leaf or for temporarily shutting down the door. The system is reset after leaving this operating mode. In this operating mode the door lock can also be permanently unlocked depending on the setting programmed at the time of commissioning. In double-leaf systems with built-in mechanical door coordinator ◆, the closing sequence is mechanically ensured after the manual opening of one leaf.

5 Operation

The automatic swing door may only be operated by a skilled person, the operator or a person instructed by the operator.

5.1 Commissioning

Before switching on the mains power supply:

- Unlock the optional mechanical door lock.
- Check that the movement area of the door leaves is free from obstructions such as racks, plant containers, umbrella stands etc.
- Switch on the mains power supply and select operating mode AUTOMATIC 1, for example.
 - The first movement after switching the power on for the first time is slow and H62 and H67 are displayed. The control system is defining the closed position of the door leaf (H62) and is checking the door leaf travel distance (H67).
 - The door is now ready for operation.

5.2 Operation with the TORMAX User Interface ♦

TORMAX User Interface

Lock ♦ for User Interface

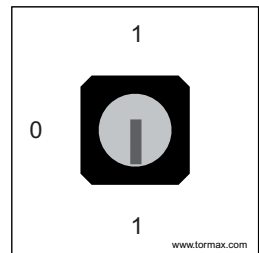
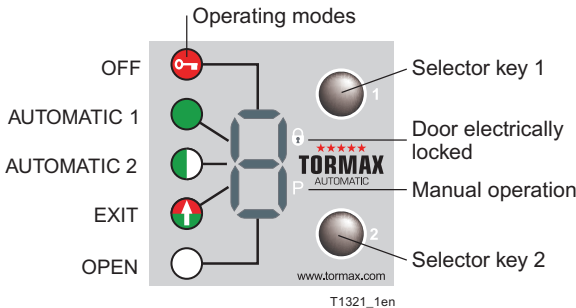

Unlocking of Operating Unit

The operating unit can be protected against unauthorized access by way of the lock ♦ or the code lock.

- Unlock lock = position 0

or

- Enter code ... / ... / ... using operating unit. The code can be determined by the engineer.

Example with code 3/3/3. Press upper selection button 3 times, then press the lower selection button 3 times and the upper selection button within 15 s. In case of entering wrong code: Wait at least 5 s. After successfully entering the code, the operating unit will be released within 60 s. The type of operation can be adjusted. Access will be automatically blocked again for 60 s after the button has been pressed for the last time.

Selection of Operating Modes

- Press selector keys 1 or 2 briefly. The corresponding operating mode symbol is illuminated.

Fault Display

E.g. H91 or E42 → See chapter 8 for the meaning of the display.

- Reset by pressing the selector key 2 briefly.

Resetting the System

- Press the selector key 2 for at least 5 seconds.

The software is restarted. The control system then conducts a calibration run, checks the travel distance and looks for the closed position. Displayed as H62 and H67.

5.3 Operation with an Operating Mode Switch ◆

Selection of Operating Modes

The switch position defines the operating mode.

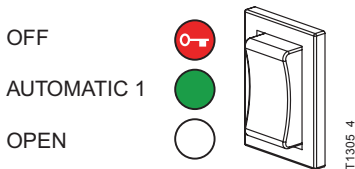

Resetting the system

- Change the operating mode in the event of a fault
or
- Cut off power supply to the system for at least 5 seconds (only system without battery unit).

5.4 Operation on Power Failure

Opening a Door using a Key Switch ◆ with a Battery Unit ◆

- Turn the key switch to the “on” position and hold in place for at least 5 seconds, then turn the key to the original position.
→ The battery is activated using the “wake up” function.

The key switch must not remain permanently in the “on” opposition.

- The door is unlocked and opened.
- The battery switches off again after the time programmed Ⓞ by the installation engineer or when the battery is fully discharged.

If required, the operating mode can be changed on the user interface during the wake-up.

5.5 Resetting the Panic Fitting ◆

- Select operating mode OFF (operating mode switch ◆, user interface ◆) or disconnect the drive from mains (installation switch, mains plug).
- Push the door leaf back into the initial position.
- Choose operating mode AUTOMATIC 1 or switch on operator.

6 Procedure in the Event of a Fault

Faults are evident from abnormal door behaviour and/or as a fault display on the user interface. Fault displays on the user interface take the form of a flashing "E" or "H" followed by two figures.

H = notification → the system can continue to be used.

E = fault → the system is stationary.

Some faults or notifications can be rectified by restarting the door drive with a software reset and/or briefly disconnecting the system from the power supply.

Fault Display and Reset Using the TORMAX User Interface

See the table in chapter 8.1 for an overview of the fault displays.

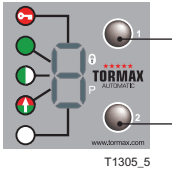

Browse through the fault display using selector key 1 upwards (to display several faults).

1. Reset the fault display, press selector key 2 (downwards) briefly.
2. Software reset: press the key for 5 seconds.

Reset of the Fault with the Operating Mode Switch

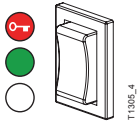

Software reset in the event of a fault: change the operating mode.

Reset of the Fault by Disconnecting the Power Supply

If the system does not have a battery unit, disconnect from the power supply for about 10 seconds.

If this does not reset the fault or if it re-occurs after a short time, you must arrange for the fault to be rectified by a skilled person from your TORMAX dealer. In this case note the fault number and inform the dealer. See the last page or the service tag on the system for the dealer's address.

7 Maintenance

The system was tested and approved by a skilled person before initial commissioning. The manufacturer recommends that you conclude a service contract in order to maintain the value of your system for as long as possible as well as to ensure the system operates reliably and safely for a long time.

Only genuine TORMAX spare part should be used. The manufacturer accepts no liability if you fail to observe this requirement. Original spare parts and original accessories guarantee the safety of use in accordance with norm EN 16005.



Warning

Possible risk of injury!

Entrapment of limbs can lead to serious injury.

- The drive must be disconnected from all power sources, including batteries during cleaning maintenance and replacement of parts.

7.1 Cleaning

- Clean casing parts, the user interface and door leaves with a damp cloth and a commercial cleaner.

7.2 Functional Checks

- Check the door system's function and safety devices **at least every 3 months**.

This will ensure that faults or hazardous changes in the system are detected at an early stage. See chapter 8.2 "Check-list for Functional Checks" for items to be checked.

- You should arrange for any defects detected during the routine checks to be rectified immediately by a TORMAX dealer (see the last page of this Manual for the address).



Warning

Potential switching malfunction in the automatic swing door.

Potential hazards – injury caused by impact or crushing.

- Secure the area around the door while checking the door's functions.

7.3 Maintenance and Testing

Maintenance and testing should only be carried out by a trained specialist following the manufacturer's instructions.

Maintenance Interval

The maintenance interval depends on the frequency of use but the system must be maintained **at least once per year**.

Scope of the Maintenance Work

The content of the maintenance work is specified by the manufacturer in an inspection list.

System Test Book



The test findings are recorded after the test in the system test book. The operator must keep it in a safe place.



8 Appendix

8.1 Fault Table

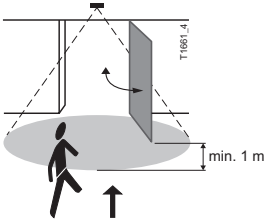
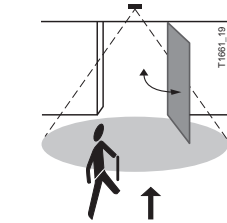
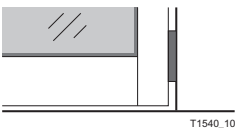
| System Behaviour | No. | Cause | Remedy/Rectification |
|---|-------------------|--|--|
| The door stops when opening. | H91 | Electronic obstacle recognition caused by persons, wind pressure and ventilation when opening. | Remove the obstruction. Avoid drafts. |
| Door reverses when closing. | H92 | Electronic obstacle recognition caused by persons, wind pressure and ventilation when closing. | Remove the obstruction. Avoid drafts. |
| The door stops repeatedly when opening. | H93 | Electronic obstacle recognition on opening in the same position by stationary obstacle. | Remove the obstruction. |
| The door stops repeatedly when closing. | H94 | Electronic obstacle recognition on closing in the same position by stationary obstacle. | Remove the obstruction. |
| Search run notified. | H62 H67 | Search run of the door after a reset or after power recovery. | Allow the search run to travel its full course. |
| Door operates at a reduced speed. | H71 | Battery operation | Wait for power recovery Switch on mains supply. |
| Door remains closed. | – | Operating mode for example OFF, EXIT or P. The door is prevented from moving by the lock. | E.g. select operating mode AUTOMATIC 1. Unlock the lock. Push the door closed briefly. |
| Door remains open. | – | Operating mode for example OPEN or P. The door is prevented from moving by the lock. | E.g. select operating mode AUTOMATIC 1. Remove the obstruction. |
| The door remains closed. | E31 | The safety facility in the opening direction is permanently active (>1 minute) or defective. | Remove objects from within the range of the sensor(s) and/or perform a software-reset |
| The door remains open | E32 | The safety facility in the closing direction is permanently active (>1 minute) or defective. | Remove objects from within the range of the sensor(s) and/or perform a software-reset |
| The door does not open or does not close. | E33 | The safety facility for the swing area is permanently active (>1 minute) or defective. | Remove objects from within the range of the sensor(s) and/or perform a software-reset |
| The door does not open or does not close. | E34 | The stop safety facility is permanently active (>1 minute) or defective. | Remove objects from within the range of the sensor(s) and/or perform a software-reset |
| The door remains open. | E41 E42 E43 | Activator inside is active > 1 min. Activator outside is active > 1 min. Key switch is active > 1 min. | Get sensor adjusted by a skilled person. Reset the key switch. |
| The door stands still | E5.. | Anomaly in the travel distance. Solid obstruction in the movement area. | Remove firm obstacle in the travelling range of the door. Perform a software-reset. |
| The door stands still | E61 E62 | Power supply is overloaded or voltage too low. | Get the power supply and connections checked by a skilled person. |
| The door stands still | E64 E65 | Drive/control system is overheated. | Wait for the automatic reset after the door/control system has cooled. Protect from direct sunlight. |
| The door stands still. | E.. E8.. | Control system shut down for safety reasons. | Perform a software-reset. |
| The door collides with a person. | – | Safety device or setting inadequate. | Shut down the system. (see chapter 2.7). |

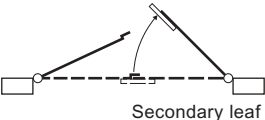
8.2 Check-List for Functional Checks

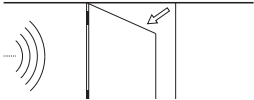
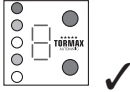
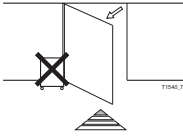
| Item To Be Checked | Procedure | Result |
|--|---|--|
| Sensors | | |
|  | <ul style="list-style-type: none"> Walk through the door directly from the front and from different directions at normal speed, starting both from the inside and outside. Activation (sensor field) at least 1 m in front of the open main closing edge. | <p>The door opens at the right time and with sufficient speed so that passage through the door is not hindered.</p> |
| Safety Sensors (if available) | | |
|  | <ul style="list-style-type: none"> Walk through the door directly from the front and from different directions at a slow speed like an infirm person, starting both from the inside and outside. | <p>The door opens and remains open until you are completely through the door.</p> |
| Swing Leaf, Door Frame | | |
|  | <ul style="list-style-type: none"> Check the glass door fillings, door edges and rubber profiles for damage. | <p>The door fillings have no sharp edges and splintered glass. The side parts and the door seals are in place and undamaged.</p> |
| Panic Fitting ◆ | | |
|  | <ul style="list-style-type: none"> Isolate the drive from the power supply (main system switch, mains plug) or select operating mode OFF. Then push the door in the direction opposite to the opening direction until the panic fitting releases the door leaf. Now push the door leaf back to the initial position. | <p>The panic fitting can be released and returned to the initial position.</p> |
| Mechanical Door Coordinator ◆ | | |
|  | <ul style="list-style-type: none"> Place the system in operating mode "P" and open the secondary door leaf halfway. Then allow the secondary door leaf to close. | <p>The primary door leaf is also pressed open by the driver flap. This leaf then remains open and motionless at about 25 degrees of the door opening until the secondary door leaf which is closing is practically closed.</p> |

| Item To Be Checked | Procedure | Result |
|---|--|--|
| Drive, Lever and Hinges | | |
|  | <ul style="list-style-type: none"> • Check the noises made while the door moves. | <p>No unusual and noticeable noise can be heard from the drive, the lever or in the region of the hinges. No significant wear is visible.</p> |
| Operating Components, Lettering and Marking | | |
|  | <ul style="list-style-type: none"> • Check the function and marking of operating controls. Check all lettering and marking for their condition. | <p>The operating controls are functioning correctly; the markings are visible and legible.</p> |
| System Vicinity | | |
|  | <ul style="list-style-type: none"> • Check access to the door and the movement area of the door leaves. | <p>Access to the door is free from objects and items likely to cause the user to trip. There are no objects such as shelves, plant containers and umbrella stands within a radius of 50 cm of the movement area.</p> |
| Mains Power Cable | | |
|  | <ul style="list-style-type: none"> • Check if the mains power cable is damaged. | <ul style="list-style-type: none"> • If damaged, get the mains power cable replaced by a skilled person. |



EC Declaration of Conformity

The manufacturer (installation company) of the complete door system declares

Manufacturer's address: _____

that the product (door system)

Type designation: _____

Serial number: _____

is in conformity with the directive 2006/42/EC (Machinery Directive)

is in conformity with regulations of the guidelines:

- 2014/35/EU (low tension)

- 2014/30/EU (electro-magnetic-compatibility)

and the following harmonised standards have been adhered to:

- EN 16005

Base document:

- Declaration of incorporation by TORMAX | LANDERT Group AG

- Risk evaluation for automatic swing doors | T-1186

Person responsible for documents

Name/address: _____

Place, date: _____

Signatory

(CE authorized person): _____

Signature: _____



the passion to drive doors

TORMAX Swing Door Drives

TORMAX Sliding Door Drives

TORMAX Folding Door Drives

TORMAX Revolving Door Drives

Producer

TORMAX
Unterweg 14
CH-8180 Bülach-Zürich
Phone +41 58 500 5000
Fax +41 58 500 5099
www.tormax.com
info@tormax.com

Installation company

(installation, repairs, maintenance)

TORMAX is a division and a registered trademark of LANDERT Group AG