

(1:20)

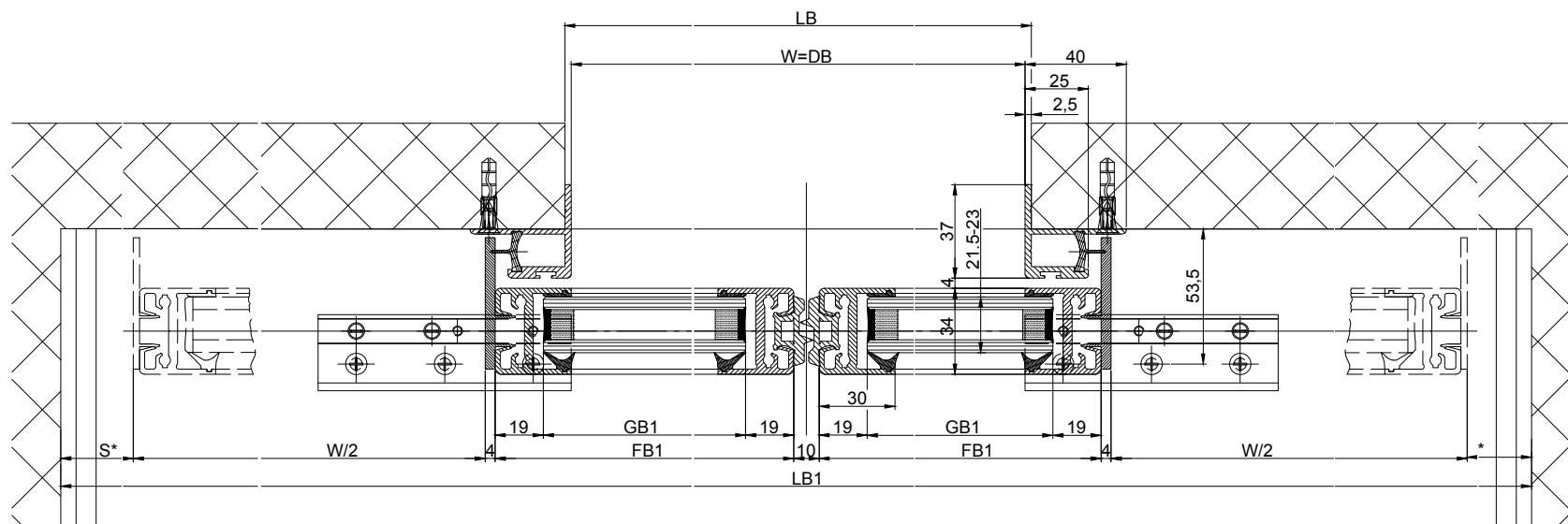

Execution
Single glazing 8.5-10mm

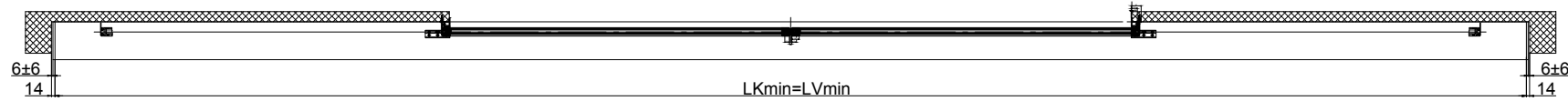
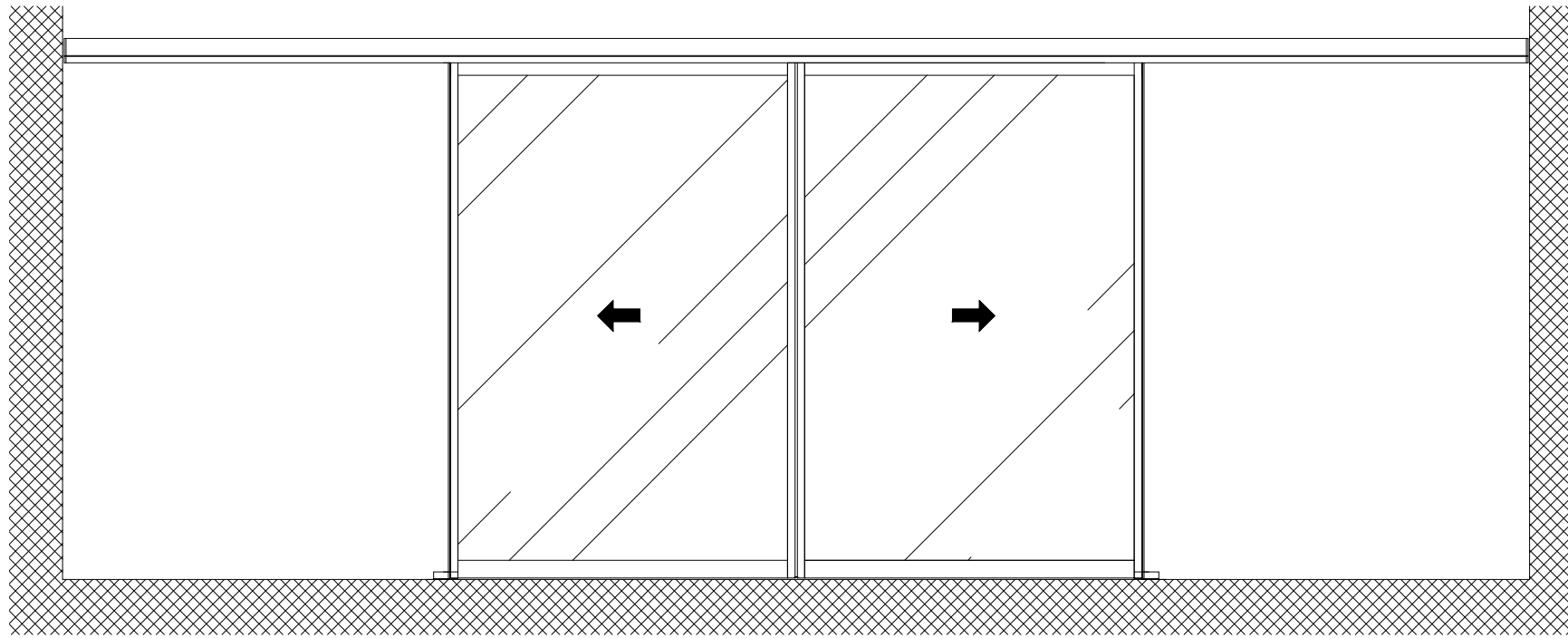
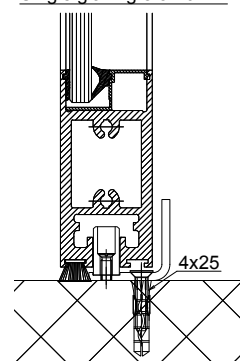

Variant continuous
CNS-Soil guide rail

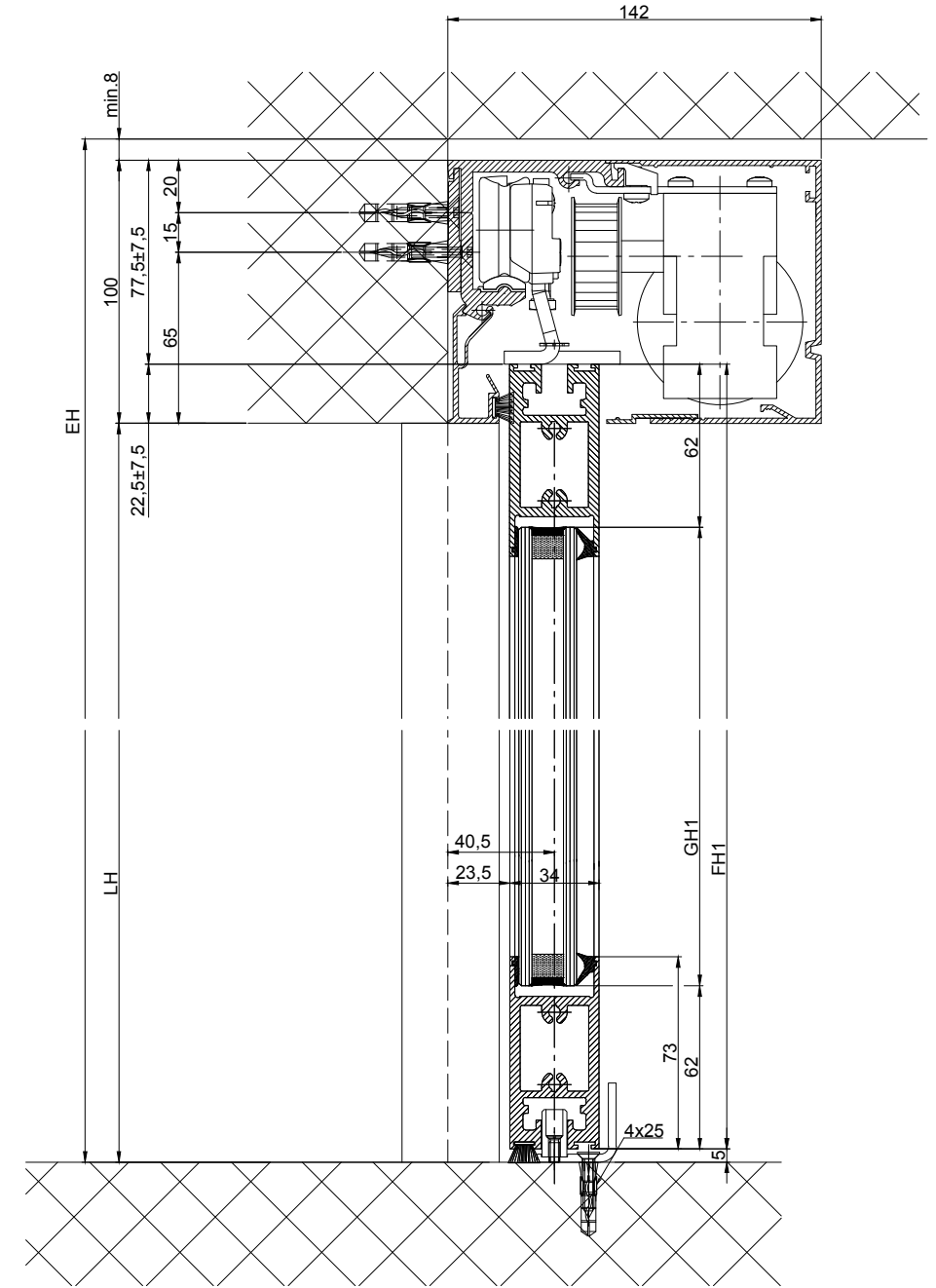
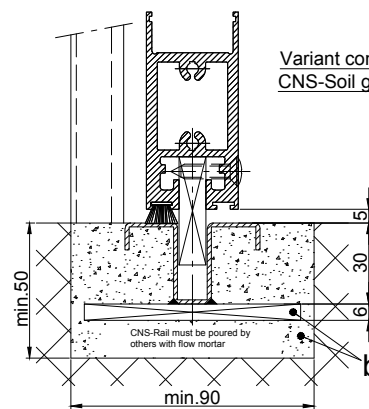

Variants of the drive cross section:

- Header profile 2101/2201/2202 (according to drawing)
- Header profile 2101/2201/2202 H100

The door leaves must be made from material which do not bear any potential risk of injury in any case of breakage (for example single sheet toughened safety glass, compound safety glass etc.). Transparent door leaves must be clearly labelled to be recognised as such.

* Safety margin according to national regulation

Anodize/color: layer thickness: Additional info:
RAL :

Object:

Customer:

Order-Nr.: Date: Release signatur:

Scale: Drawn: 28.11.19 MURO
% ok to print

Operatortyp: Profilsystem Execution
2203 LR22B without fixedwing, lintel

TORMAX AUTOMATIC TORMAX a division of LANDERT Group AG CH-8180 Bülach-Zürich Document number: T3_390_776 Index

b Executed on site

$$LB1=2W+68+2s$$

$$W=(LB1-2s-68)/2$$

$$LKmin=Lvmin=LB1-28$$

$$FB1=W/2+25$$

$$GB1=FB1-38$$

$$FH1=LH1+17.5$$

$$GH1=FH1-124$$