

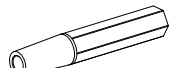

----- Zusatzverschalung

X	-3 ... +147
Z	57 ... 117 ± 3
	63 ... 123

d min.	c+570	$\sqrt{a^2+(x+74)^2+570}$
--------	-------	---------------------------

Objekt:				
Kunde:				
AuftragsNr.:		Datum:		Freigabevisum:
	Massstab	Gezeichnet	11.02.2021	REFL
		Gut zum Druck		
Antriebstyp :		Ausführung:		
iMotion 1301 DFT Gehäuse IP68 Sturzmontage Gleithebel 350 mm				
		TORMAX a Division of LANDERT Group AG CH-8180 Bülach-Zürich		DokumentenNr.: T3-386-84
				Index E