



Vela Industrial

HYDRAULIC BARRIER FOR INDUSTRIAL BEAMS UP TO 7,5M



- The operation through oil and the inside lubrication of all mechanical components grant a longer life.
- Possibility to add a solar panel SUNNY KIT (only 24V version) .
- Adjustable mechanical limit switches.
- Cataphoresis treated, polyester painted steel casing for long time lasting.
- Stainless steel casing available.
- New oval aluminium beam LINEAR with double protection rubber and optional LED light KIT (CLED 12715215 + TLED 12715216). Also available modular beam SPLIT+JUICE (New) with connection joint for easy transportation.
- Version with double rectangular beam fixing (VELA INDUSTRIAL) with rectangular beam or LINEAR beam (on request)
- On request version with fixing for rectangular or oval beam linear (VELA INDUSTRIAL)



Double beam fixation with fork



By pass valves



Bright LEDs. Flashing lamp . Opening with key



Case opening.

CODE	NAME	OPENING TIME	MAX BEAM LENGTH (m)	PUMP (l)	FREQUENCY OF USE (%)	PCS FOR PALLET
11701120	VELA INDUSTRIAL 230 V	8,0 sec. - 12 sec.	7,0	2,0	70	8
11701125	VELA INDUSTRIAL 230 V-F with fork	8,0 sec. - 12 sec.	7,5	2,0	70	8
11701130	VELA INDUSTRIAL 24 V	8,0 sec. - 12 sec.	7,0	2,0	85	8
11701135	VELA INDUSTRIAL 24 V-F with fork	8,0 sec. - 12 sec.	7,5	2,0	85	8

230v version with GATE 1 ROLL control unit.

Foundation plate

"F" version (Double fork fixing oval beam for L)

Note: To choose left (SX) or right (DX): Vela operator is considered right-hinged if, when looking at the casing door accessing the motor, the beam is on the right;

To use the rectangular beam (over 6m) SEA recommends the installation of the fork coupling Kit (Fork).

LINEAR beam for VELA INDUSTRIAL.

SQXF beam for VELA INDUSTRIAL F with fork

Reported opening times are without slowdown

MODULAR BEAM WITH JOINT

CODE	DESCRIPTION	BEAM
11903115 +11903125	SPLIT 4 m + JUICE 2 m	6 m
11903115 +11903120	SPLIT 4 m + JUICE 3 m	7 m

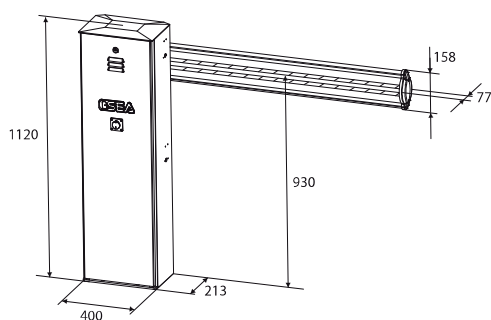

PACKAGE

VELA INDUSTRIAL

- N.1 Operator VELA INDUSTRIAL
- N.1 gate 1 Control unit
- N.1 Installation accessories Kit
- N.1 Installation instructions and general notice
- N.1 Foundation plate
- N.1 Warning signboard

