



SFS

Design air curtain for revolving doors, with intelligent control

- For revolving doors
- Vertical mounting
- Height: 2,2 m

⚡ Electrical heat: 8–23 kW

💧 Water heat WL

Application

The SFS is an air curtain with many clever functions, specially designed for revolving doors. The air curtain is mounted vertically and its curved design integrates neatly with the door. SFS efficiently protects the exposed area just above the floor.

A revolving door prevents continuous drafts but still lets in a certain amount of cold air at every rotation. The air curtain prevents the cold air from penetrating and gives good heating comfort.

Design

The SFS has a curved design that follows the shape of the revolving door and is available in powder-coat painted or stainless steel. The product key offers many options for the design and finish of the air curtain.

Product specifications

- Prepared for the SIRE control system whose pre-programmed default settings and many features make it easy to install and use the air curtain. Read more about the SIRE controls package in the "Controls" section.
- Customised production based on the product key.
- Standard length is 2200 mm. Lengths up to 3 m can be ordered according to the product key (extension without fans). Extension hoods, for heights up to 4 m, are available as an accessory.
- The air curtain is mounted to the left of the revolving door. Air curtains for installation to the right can be specially ordered.
- Available in polished high gloss, polished or brushed stainless steel. Also available in powder coated steel, any RAL/NCS colour. Aluminium louvres. Colour intake grille: grey, RAL 7046.



Design and specifications are subject to change without notice.

Technical specifications

⚡ Electrical heat - SFS E

Type	Output steps [kW]	Airflow* ¹ [m ³ /h]	Δt* ³ [°C]	Sound level* ² [dB(A)]	Voltage [V] Amperage [A] (control)	Voltage [V] Amperage [A] (heat)	Length* ⁶ [mm]	Weight [kg]
SFS23E08	2,7/5,4/8,1	1050/2300	23/11	60	230V~/2,3	400V3~/11,7	2200	75
SFS30E12	3,9/7,8/11,7	1400/3000	25/12	61	230V~/3,1	400V3~/16,9	2200	80
SFS38E16	5,4/10,8/16,2	1800/3800	27/13	62	230V~/4,8	400V3~/23,4	2200	80
SFS56E23	7,8/15,6/23,4	2700/5600	26/12	63	230V~/7,0	400V3~/33,8	2200	90

💧 Water heat - SFS WL, coil for low water temperature (≤80 °C)

Type	Output* ⁴ [kW]	Output* ⁵ [kW]	Airflow [m ³ /h]	Δt* ^{3,4} [°C]	Δt* ^{4,5} [°C]	Water volume [l]	Sound level* ² [dB(A)]	Voltage [V]	Amperage [A]	Length* ⁶ [mm]	Weight [kg]
SFS23WL	13,3	22,3	1050/2300	22/17	37/29	3,0	60	230V~	2,3	2200	75
SFS30WL	19,9	33,0	1400/3000	25/20	41/33	4,4	61	230V~	3,1	2200	80
SFS38WL	23,1	39,1	1800/3800	23/18	38/31	4,4	62	230V~	4,8	2200	80
SFS56WL	29,4	49,7	2700/5600	20/16	34/26	4,4	63	230V~	7,0	2200	90

*¹) Lowest/highest airflow of totally 5 fan steps.

*²) Conditions: Distance to the unit 5 metres. Directional factor: 2. Equivalent absorption area: 200 m².

*³) Δt = temperature rise of passing air at maximum heat output and lowest/highest airflow.

*⁴) Applicable at water temperature 60/40 °C, air temperature, in +18 °C.

*⁵) Applicable at water temperature 80/60 °C, air temperature, in +18 °C.

*⁶) Standard height. Max. height 3000 mm (extension without fans).

Protection class: IP20.

CE compliant.

Ordering

Select air curtain

To select which air curtain to order, multiply the width with the height of the opening of the revolving door, to get the surface of the opening. To create comfort in the entrance area between 3,5 and 5 kW heating per square metre of opening, depending on the lowest outdoor temperature, is needed.

Product key

Type - Connection position - Total height - Material / colour

Example: SFS30E12 - 1 - 2800 mm - P

Type	See Technical specifications.
Connection position	A or B, see fig.
Total height	Min. height 2200 mm. Max height 3000 mm. Extension without fans.
Material/colour	P = Polished stainless steel B = Brushed stainless steel MP = Mirror polished stainless steel State RAL-kod = Powder coating RAL State NCS-kod = Powder coating NCS

Connections position

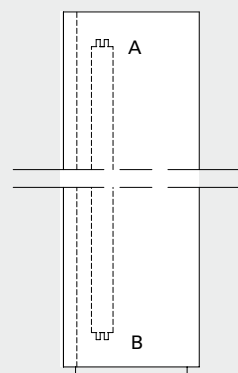

SFS

Dimensions

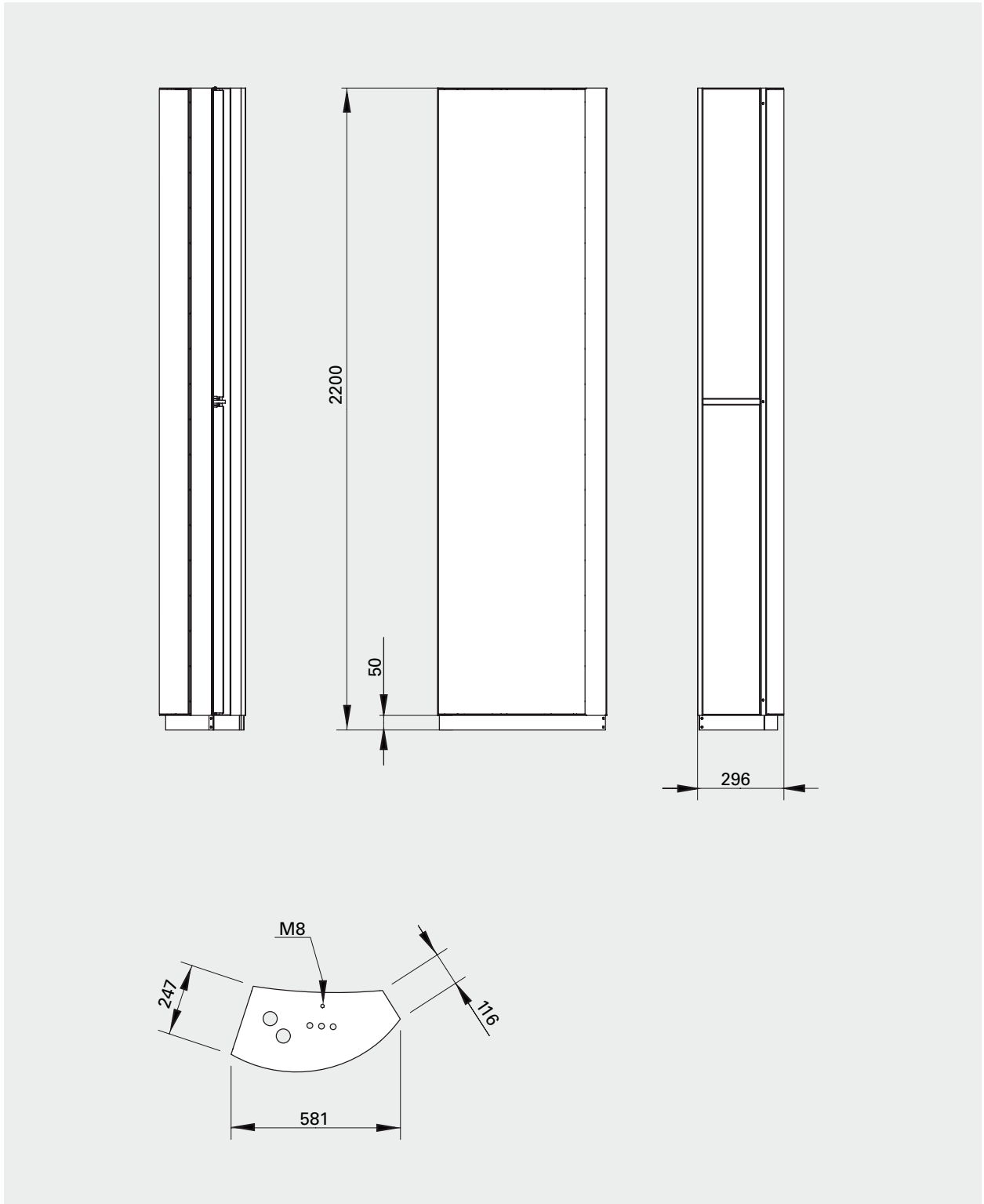

Mounting and connection

Mounting

The air curtain is mounted to the left of the door seen from inside. The unit has a curved design which makes it an integrated part of the door. When ordering, state whether electricity and/or water connections are made from above or below.

The air curtain is installed on adjustable feet which makes it possible to compensate for any surface undulations. The feet are attached to the floor with fasteners appropriate to the surface and covered by a frame. The air curtain must always be secured at the top.

Connection

The PC board SIRE is built into the air curtain on delivery and is equipped with modular connectors for easy connection of external components. Read more about the SIRE control system in the "Controls" section.

Unit with electrical heating

The electrical connection may be done from above or below, according to ordering key. Control (230V~) and power supply for heat (400V3~) should be connected to a terminal block. For units with electrical heating, power and control should be supplied separately.

Unit with water heating

The electrical connection may be done from above or below, according to ordering key. Control (230V~) should be connected to a terminal block.

Water connection can be made from above and below, according to the order key, via DN25 (1"), internal thread connections. Flexible hoses are available as an accessory.

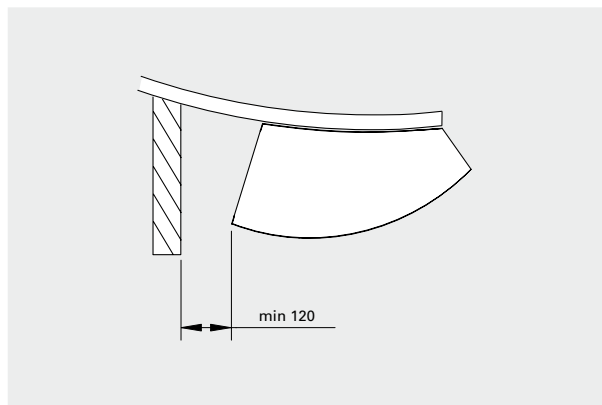

Minimum distances



Accessories

SFSEH, extension hood

Extends the unit, adapting it to the installation. Height 100-1000 mm. Special order to required dimension.

FH1025, flexible hose

Flexible hose (DN25, 1" inside thread) for easy connection to the pipe system.

Type	Description
SFSEH	Extension hood
FH1025	Flexible hose DN25, inside thread, length 1 m

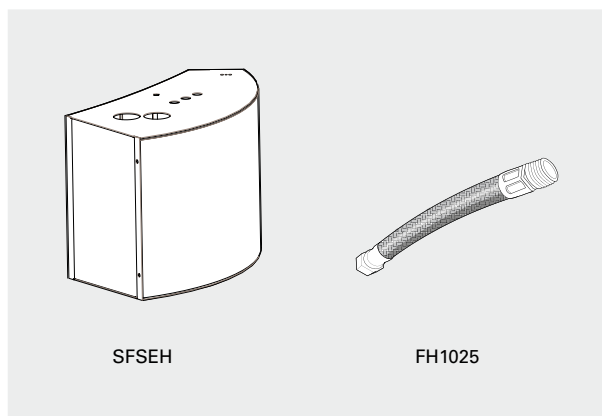

SFSEH

FH1025

Controls

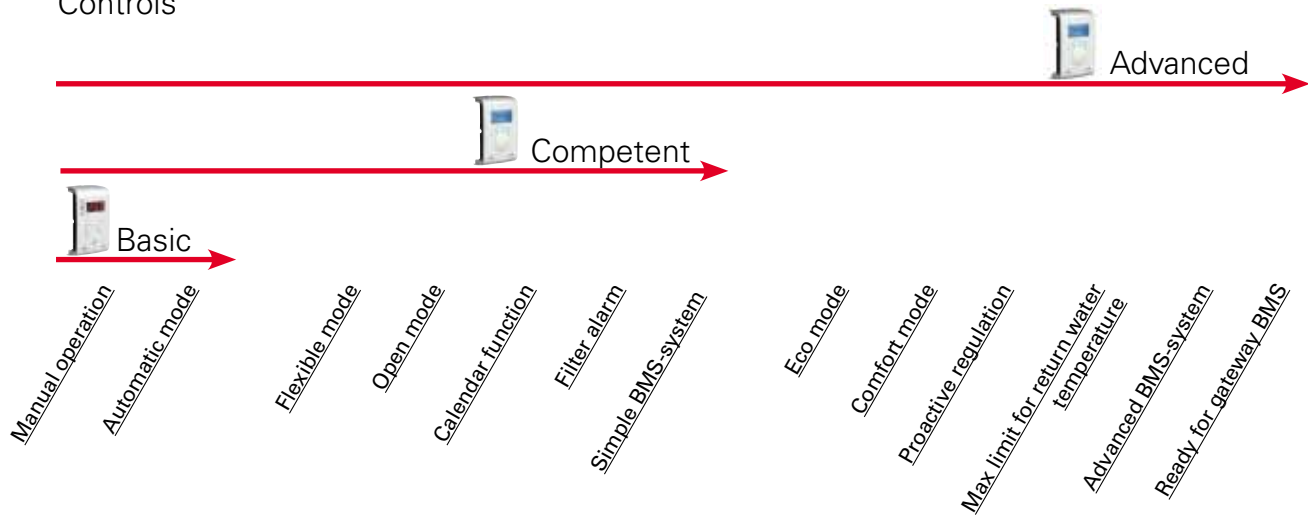

This air curtain is supplied with an integrated PC board SIRE. There are three different levels with different functionality to choose from, Basic, Competent or Advanced. Read more about the SIRE control system in the "Controls" section.

Type	Description
SIREB	Control system SIRE Basic
SIREAC	Control system SIRE Competent
SIREAA	Control system SIRE Advanced

Water control

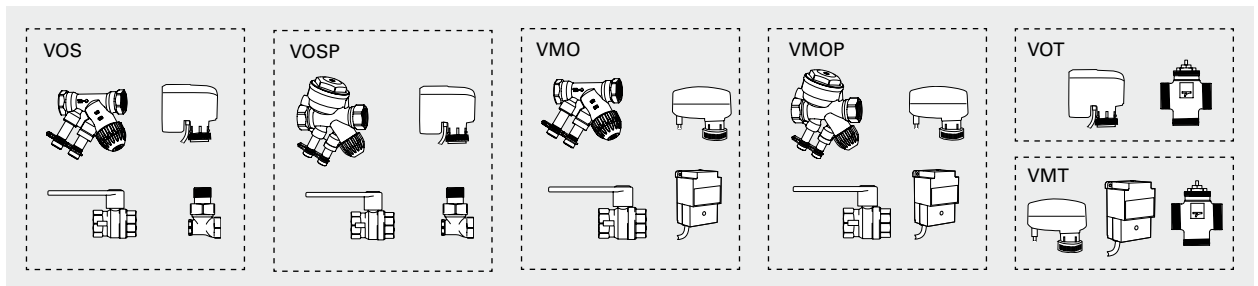

Valve kit VOS(P), VOT, VMO(P) or VMT is used to control the water flow. For more information see the "Controls" section.

Type	Description
VOS15LF	Valve kit on/off, low flow, DN15
VOS15NF	Valve kit on/off, DN15
VOS20	Valve kit on/off, DN20
VOS25	Valve kit on/off, DN25
VOSP15LF	Pressure independent valve kit, low flow, DN15
VOSP15NF	Pressure independent valve kit, DN15
VOSP20	Pressure independent valve kit, DN20
VOSP25	Pressure independent valve kit, DN25
VOT15	Three way control valve and actuator on/off, DN15
VOT20	Three way control valve and actuator on/off, DN20
VOT25	Three way control valve and actuator on/off, DN25

Type	Description
VMO15LF	Modulating valve kit, low flow, DN15
VMO15NF	Modulating valve kit, DN15
VMO20	Modulating valve kit, DN20
VMO25	Modulating valve kit, DN25
VMOP15LF	Pressure independent and modulating valve kit, low flow, DN15
VMOP15NF	Pressure independent and modulating valve kit, DN15
VMOP20	Pressure independent and modulating valve kit, DN20
VMOP25	Pressure independent and modulating valve kit, DN25
VMT15	Three way control valve and modulating actuator, DN15
VMT20	Three way control valve and modulating actuator, DN20
VMT25	Three way control valve and modulating actuator, DN25

Output charts water

			Supply water temperature: 80 °C Room temperature: +18 °C Outlet air temperature: +35 °C*1				Water temperature: 80/60 °C Room temperature: +18 °C			
Type	Fan position	Airflow [m³/h]	Output [kW]	Return water temp. [°C]	Water flow [l/s]	Pressure drop [kPA]	Output*2 [kW]	Outlet air temp. [°C]	Water flow [l/s]	Pressure drop [kPA]
SFS23WL	max	1800	10,3	28,2	0,05	1,1	18,9	49,2	0,23	15,2
	min	900	5,2	29,5	0,03	0,3	11,6	56,2	0,14	6,4
SFS30WL	max	2400	13,8	26,3	0,06	0,8	28,4	53,2	0,35	15,7
	min	1200	6,8	29,2	0,03	0,2	17,1	60,3	0,21	6,4
SFS38WL	max	3600	20,6	28,7	0,10	1,8	37,6	49,0	0,46	25,8
	min	1800	10,3	27,0	0,05	0,5	23,2	56,2	0,28	10,9
SFS56WL	max	5400	30,9	34,0	0,16	4,3	48,6	44,7	0,59	41,0
	min	2700	15,4	26,3	0,07	1,0	30,8	51,9	0,38	18,1

			Supply water temperature: 70 °C Room temperature: +18 °C Outlet air temperature: +35 °C*1				Water temperature: 70/50 °C Room temperature: +18 °C			
Type	Fan position	Airflow [m³/h]	Output [kW]	Return water temp. [°C]	Water flow [l/s]	Pressure drop [kPA]	Output*2 [kW]	Outlet air temp. [°C]	Water flow [l/s]	Pressure drop [kPA]
SFS23WL	max	1800	10,3	31,4	0,06	1,8	15,2	43,1	0,19	10,6
	min	900	5,1	29,7	0,03	0,5	9,3	48,7	0,11	4,5
SFS30WL	max	2400	13,7	27,5	0,08	1,3	22,7	46,1	0,28	10,8
	min	1200	6,9	29,1	0,04	0,4	13,8	52,1	0,17	4,5
SFS38WL	max	3600	20,6	32,0	0,13	3,1	30,1	42,8	0,37	17,8
	min	1800	10,3	27,5	0,06	0,8	18,6	48,7	0,23	7,6
SFS56WL	max	5400	30,9	38,0	0,23	8,3	38,8	39,3	0,47	28,0
	min	2700	15,5	28,7	0,09	1,6	24,6	45,1	0,30	12,5

			Supply water temperature: 60 °C Room temperature: +18 °C Outlet air temperature: +35 °C*1				Water temperature: 60/40 °C Room temperature: +18 °C			
Type	Fan position	Airflow [m³/h]	Output [kW]	Return water temp. [°C]	Water flow [l/s]	Pressure drop [kPA]	Output*2 [kW]	Outlet air temp. [°C]	Water flow [l/s]	Pressure drop [kPA]
SFS23WL	max	1800	10,3	35,8	0,10	4,0	11,4	36,7	0,14	6,6
	min	900	5,2	30,3	0,04	0,9	7,0	41,0	0,08	2,8
SFS30WL	max	2400	13,7	31,2	0,11	2,5	17,0	39,0	0,21	6,7
	min	1200	6,9	29,0	0,05	0,7	10,4	43,7	0,13	2,9
SFS38WL	max	3600	20,6	36,4	0,21	7,1	22,4	36,5	0,27	10,9
	min	1800	10,3	28,7	0,08	1,3	14,0	41,0	0,17	4,8
SFS56WL	max	5400	30,9	43,3	0,45	26,4	28,7	33,8	0,35	17,0
	min	2700	15,5	32,6	0,14	3,3	18,5	38,4	0,23	7,8

			Supply water temperature: 55 °C Room temperature: +18 °C Outlet air temperature: +35 °C*1				Water temperature: 55/35 °C Room temperature: +18 °C			
Type	Fan position	Airflow [m³/h]	Output [kW]	Return water temp. [°C]	Water flow [l/s]	Pressure drop [kPA]	Output*2 [kW]	Outlet air temp. [°C]	Water flow [l/s]	Pressure drop [kPA]
SFS23WL	max	1800	10,3	39,0	0,16	8,3	9,4	33,5	0,11	4,8
	min	900	5,2	31,1	0,05	1,3	5,8	37,1	0,07	2,1
SFS30WL	max	2400	13,7	33,8	0,16	4,3	14,2	35,6	0,17	5,0
	min	1200	6,9	29,3	0,06	0,9	8,7	39,5	0,11	2,1
SFS38WL	max	3600	20,6	39,5	0,32	15,0	18,5	33,3	0,22	7,9
	min	1800	10,3	30,7	0,10	2,1	11,6	37,1	0,14	3,5
SFS56WL	max	5400	30,9	46,8	0,91	94,4	23,7	31,0	0,29	12,3
	min	2700	15,4	35,2	0,19	5,9	15,3	34,9	0,19	5,7

*1) Recommended outlet air temperature for good comfort and optimized output.

*2) Nominal output at given supply and return water temperature.

See www.frico.se for additional calculations.

Wiring diagrams

Unit with water heating

