



# Saturn 600

**GEARMOTOR FOR RESIDENTIAL SLIDING GATES.**



- Solid, die-cast aluminum body
- OIL version with oil lubrication of the gears for longer life
- High quality mechanical or inductive limit switches (On request magnetic limit switches on "MAG" version)
- Release system with robust aluminium lever with lock in case of power cut
- Optional external release with metal box
- Standard encoder to comply with the rules (Optional on SATURN E)
- Standard, mechanical twin-disc clutch (OIL version)
- Micro-switch for stop function on release lever in case of assistance (OIL version)
- On request extra base painting (SM600 colour)
- Optional external release system with stainless steel cable and safety box



In option release with aluminium lever and lock (optional for SATURN E and G1)



The SATURN OIL versions are with oil lubrication of the gears for max duration



Mechanical twin-disc clutch (only for SATURN OIL)

46

CODE	NAME	MAX GATE WEIGHT (KG)	MAX LEAF LENGTH	MAX CYCLES/HOUR	PCS FOR PALLET
12400210	<b>SATURN 600 OIL</b> inductive limit switch	600	6 m	25	25
12400215	<b>SATURN 600 OIL</b> mechanical limit switch	600	6 m	25	25
12400207	<b>SATURN 600 G1</b> mechanical limit switch	600	6 m	25	25
12400205	<b>SATURN 600 E*</b> with SLIDE control unit	600	6 m	25	25
12715255	supplementary painted base				

For versions with magnetic limit switch write "MAG" after the code  
 \* SLIDE control units max. 10 users with fix code or 800 users with rolling code

## ACCESSORIES



65000055

**OILGS** yellow oil for SATURN (5 L)



16101047

**PZ20** pinion Z 20 mod 4 for SATURN



16101115

**PZ13T** pinion Z13 for SATURN



12715240

**Cover INOX** stainless cover for external release to combine with SECSAT

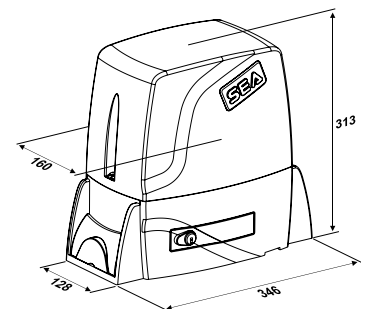

12710340

**SECSAT** security box and external release with cable of 2,5 m



12710605

**Lock** with DIN and lock cover (for SATURN G1 and E)



12710615

**Cover lock** for basic lock (for SATURN G1 and E)



12710405

**Microswitch** on release lever for STOP function (for SATURN G1 and E)



11203005

**ENC** kit Encoder for SATURN E



NB: Version SATURN oil whit GATE 1 ROLL control unit, serial encoder, mechanical clutch and oil lubrication, microswitch on lever of release and cover lock  
 The SATURN E G1 whit GATE 1 control unit, base of carter no painted, without encoder, without microswitch, without mechanical clutch, grease lubrication  
 Version SATURN whit mechanical clutch has manual release with metal lock  
 For SATURN 600 OIL



For SATURN G1

