



PA2500

Stylish air curtain for entrances, with intelligent control

- Recommended installation height 2,5 m*
- Horizontal mounting
- Lengths: 1, 1,5 and 2 m

⚡ Electrical heat: 5 - 16 kW

💧 Water heat



Optimized airflow with Thermozone technology.

Application

The PA2500 creates a temperature dividing air barrier that effectively prevents cold drafts and gives excellent heating comfort in door ways, such as shops, offices and public offices.

The air curtain has many intelligent and energy saving features which provide fully automatic protection for the entrance, adaptable to each area of use.

Design

The PA2500 has a modern and stylish design developed to fit all entrances. A recess on the upper side of the unit with electrical heating simplifies installation and makes it more attractive. The front can be finished in any colour to perfectly match the environment.

Air velocity profile

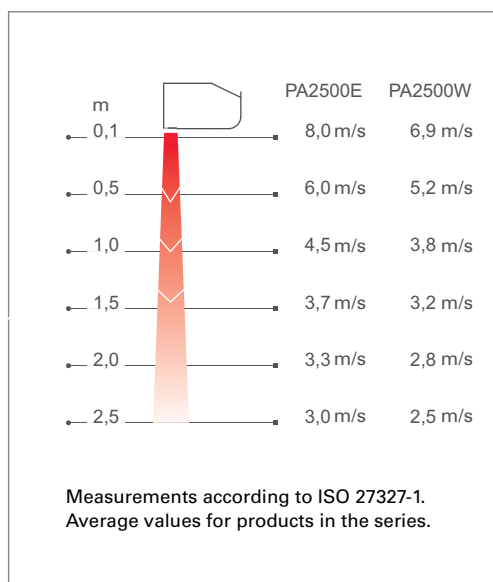

Product specifications

- Prepared for the SIRE control system whose pre-programmed default settings and many features make it easy to install and use the air curtain. Read more about the SIRE controls package in the "Controls" section.
- 3 fan steps and 3 electrical heating steps, which give more even comfort and extra energy savings.
- Wall brackets included.
- The front is easy to remove, which facilitates installation and allows easy maintenance.
- Corrosion proof housing made of hot zinc-plate and powder enamelled steel panels. Colour front: white, RAL 9016, NCS S 0500-N. Colour grille, rear section, ends and brackets: grey, RAL 7046.

*) Recommended installation height varies depending on the relevant premises.

Technical specifications

⚡ Electrical heat - PA2500 E

Type	Output steps [kW]	Airflow*1 [m ³ /h]	Δt^{*3} [°C]	Sound level*2 [dB(A)]	Voltage motor [V]	Amperage motor [A]	Voltage [V] Amperage [A] (heat)	Length [mm]	Weight [kg]
PA2510E05	1,7/3,3/5	900/1450	17/10,5	42/51	230V~	0,5	400V3~/7,2	1050	19
PA2510E08	3/5/8	900/1450	27/16,5	42/51	230V~	0,5	400V3~/11,5	1050	20
PA2515E08	2,7/5,4/8	1400/2200	17,5/11	40/52	230V~	0,7	400V3~/11,5	1560	30
PA2515E12	3,9/8/12	1400/2200	26/16,5	40/52	230V~	0,7	400V3~/17,3	1560	32
PA2520E10	3,4/6,7/10	1800/2900	17/10,5	43/53	230V~	1,0	400V3~/14,4	2050	36
PA2520E16	6/10/16	1800/2900	27/16,5	43/53	230V~	1,0	400V3~/23,1	2050	40

💧 Water heat - PA2500 W

Type	Output*4 [kW]	Airflow*1 [m ³ /h]	$\Delta t^{*3,4}$ [°C]	Water volume [l]	Sound level*2 [dB(A)]	Voltage motor [V]	Amperage motor [A]	Length [mm]	Weight [kg]
PA2510W	4,7	900/1300	12/11	0,71	42/53	230V~	0,45	1050	17,5
PA2515W	9,2	1250/2100	16/13	1,09	41/54	230V~	0,6	1560	26
PA2520W	11,5	1800/2600	15/13	1,42	43/55	230V~	0,9	2050	35

*1) Lowest/highest airflow of totally 3 fan steps.

*2) Conditions: Distance to the unit 5 metres. Directional factor: 2. Equivalent absorption area: 200 m². At lowest/highest airflow.

*3) Δt = temperature rise of passing air at maximum heat output and lowest/highest airflow.

*4) Applicable at water temperature 60/40 °C, air temperature, in +18 °C.

Protection class for units with electrical heating: IP20.

Protection class for units with water heating: IP21.

CE compliant.

PA2500

Dimensions

All models

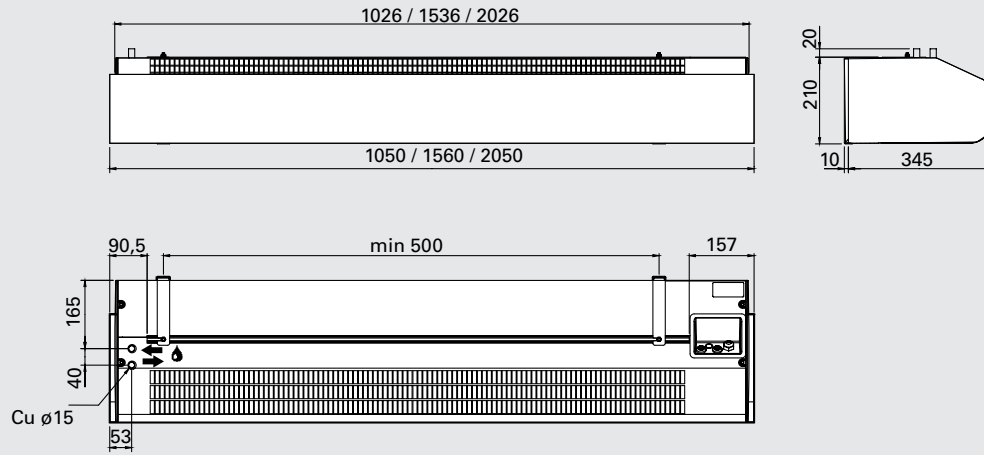

2 metre units

Unit with water heating

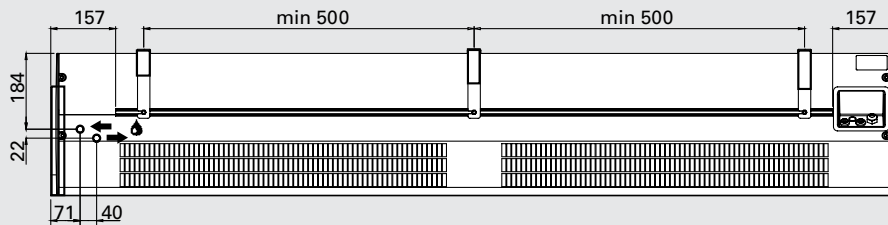

Unit with electrical heating

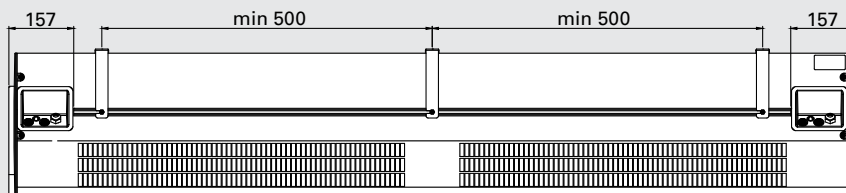

Mounting and connection

Mounting

The air curtain is installed horizontally with the supply air grille facing downwards as close to the door as possible.

Different installation options are available; brackets for wall mounting (included in delivery) and hanging brackets or threaded bars for ceiling mounting.

For the protection of wider doorways, several units can be mounted next to each other. Minimum distance from outlet to floor for electrically heated units is 1800 mm.

Connection

The PC board SIRE is built into the air curtain on delivery and is equipped with modular connectors for easy connection of external components. Read more about the SIRE control system in the "Controls" section.

Unit with electrical heating

The electrical connection is made on the top of the unit. Control (230V~) and power supply for heat (400V3~) should be connected to a terminal block in the terminal box. 2-metre and longer units require dual power supplies.

Unit with water heating

Connected via the built-in control board SIRE with 1,5 m cord and plug.

The water coil is connected on the upper side of the unit with $\varnothing 15$ mm smooth copper pipe with a suitable coupling or soldering.

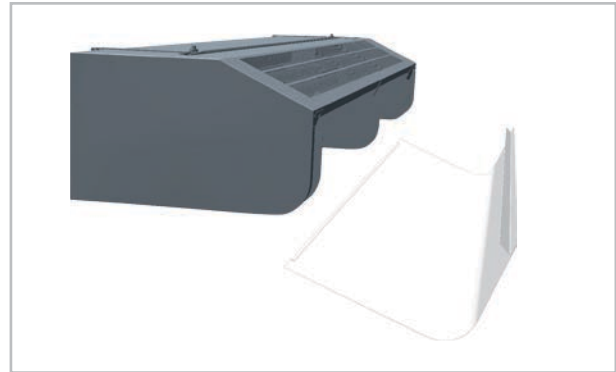

The front is easy to remove, which facilitates installation and allows easy maintenance.

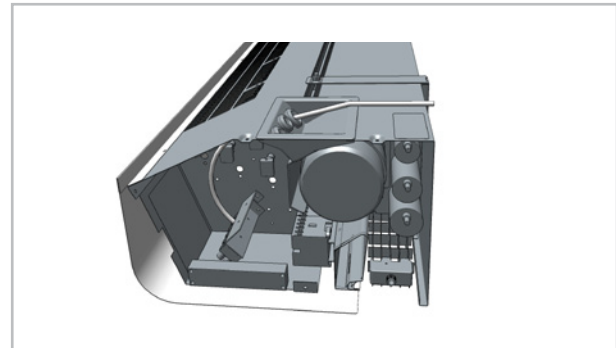

Thanks to a recess on the upper side of units with electrical heating, the wiring to and inside the unit is greatly simplified.

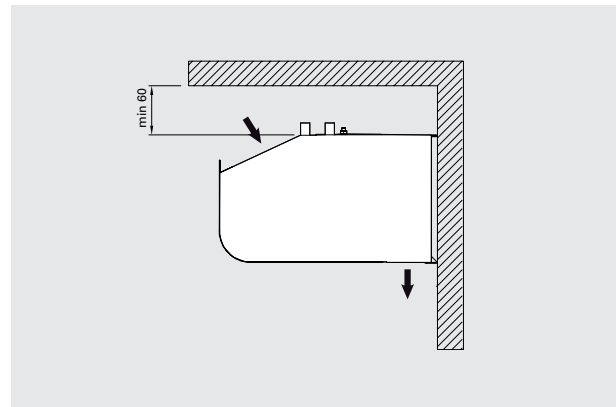

Minimum distances

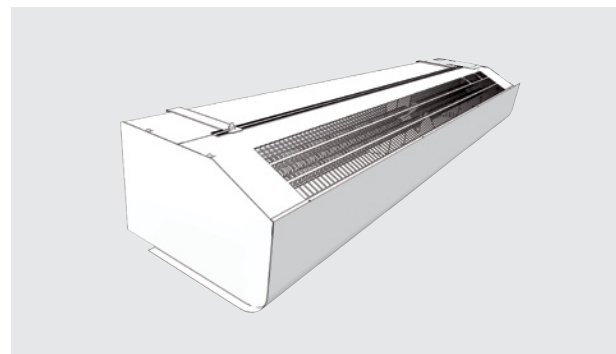

Wall brackets included.

PA2500

Accessories

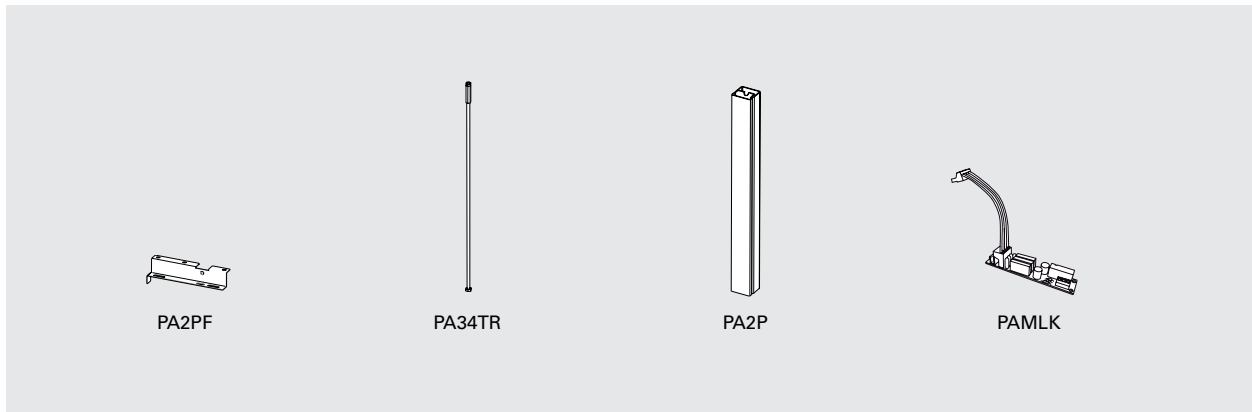

PA2PF, ceiling mounting brackets
Mountings for installing the unit in the ceiling using hanging brackets or threaded bars (not included).

PA34TR, threaded bars
Threaded bars for installing unit on to a ceiling. Length 1 m. Used together with ceiling mounting brackets PA2PF.

PA2P, hanging brackets
Hanging brackets for installing the unit suspended from the ceiling. Length 1 m. The hanging brackets are covered by a white plastic trim to cover the cables. The brackets may be cut to shorter length, if required. Used together with ceiling mounting brackets PA2PF.

PAMLK, motor alarm board
Used for units that do not have withdrawn thermal contact. For units with SIRE, connect the board to the SIRE automatic for motor alarm indication. For other units the potential free alarm switch for external alarm is used.

Type	Description	Quantity included	Length
PA2PF15	Ceiling mounting brackets for 1 and 1,5 metre units	4 pcs	
PA2PF20	Ceiling mounting brackets for 2 metre units	6 pcs	
PA34TR15	Threaded bars for 1 and 1,5 metre units	4 pcs	1 m
PA34TR20	Threaded bars for 2 metre units	6 pcs	1 m
PA2P15	Hanging brackets for 1 and 1,5 metre units	2 pcs	1 m
PA2P20	Hanging brackets for 2 metre units	3 pcs	1 m
PAMLK	Motor alarm board		

Controls

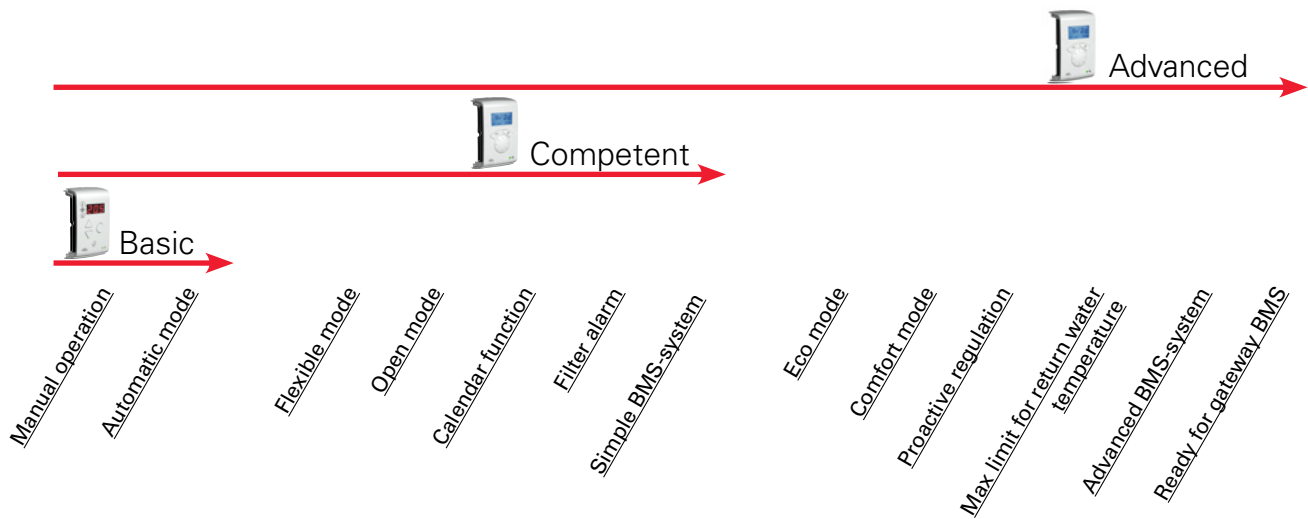

This air curtain is supplied with an integrated PC board SIRE. There are three different levels with different functionality to choose from, Basic, Competent or Advanced. Read more about the SIRE control system in the "Controls" section.

Type	Description
SIREB	Control system SIRE Basic
SIREAC	Control system SIRE Competent
SIREAA	Control system SIRE Advanced

Water control

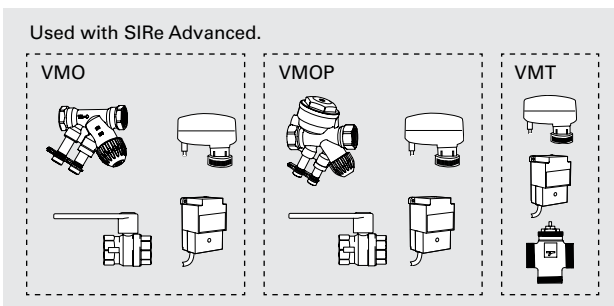
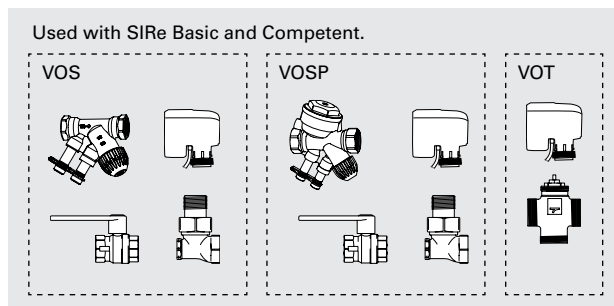

Valve kit VOS(P), VOT, VMO(P) or VMT is used to control the water flow. For more information see the "Controls" section.

Type	Description
VOS15LF	Valve kit on/off, low flow, DN15
VOS15NF	Valve kit on/off, DN15
VOS20	Valve kit on/off, DN20
VOS25	Valve kit on/off, DN25
VOSP15LF	Pressure independent valve kit, low flow, DN15
VOSP15NF	Pressure independent valve kit, DN15
VOSP20	Pressure independent valve kit, DN20
VOSP25	Pressure independent valve kit, DN25
VOT15	Three way control valve and actuator on/off, DN15
VOT20	Three way control valve and actuator on/off, DN20
VOT25	Three way control valve and actuator on/off, DN25

Type	Description
VMO15LF	Modulating valve kit, low flow, DN15
VMO15NF	Modulating valve kit, DN15
VMO20	Modulating valve kit, DN20
VMO25	Modulating valve kit, DN25
VMOP15LF	Pressure independent and modulating valve kit, low flow, DN15
VMOP15NF	Pressure independent and modulating valve kit, DN15
VMOP20	Pressure independent and modulating valve kit, DN20
VMOP25	Pressure independent and modulating valve kit, DN25
VMT15	Three way control valve and modulating actuator, DN15
VMT20	Three way control valve and modulating actuator, DN20
VMT25	Three way control valve and modulating actuator, DN25

Water control

Choose valve kit

Water heated units that are controlled by SIRE are supplemented with valve kits. It's easy to choose the right valve kit. Look at the guide for the level of SIRE chosen - Basic, Competent or Advanced and select the valve kit which suits the system requirements and characteristics.

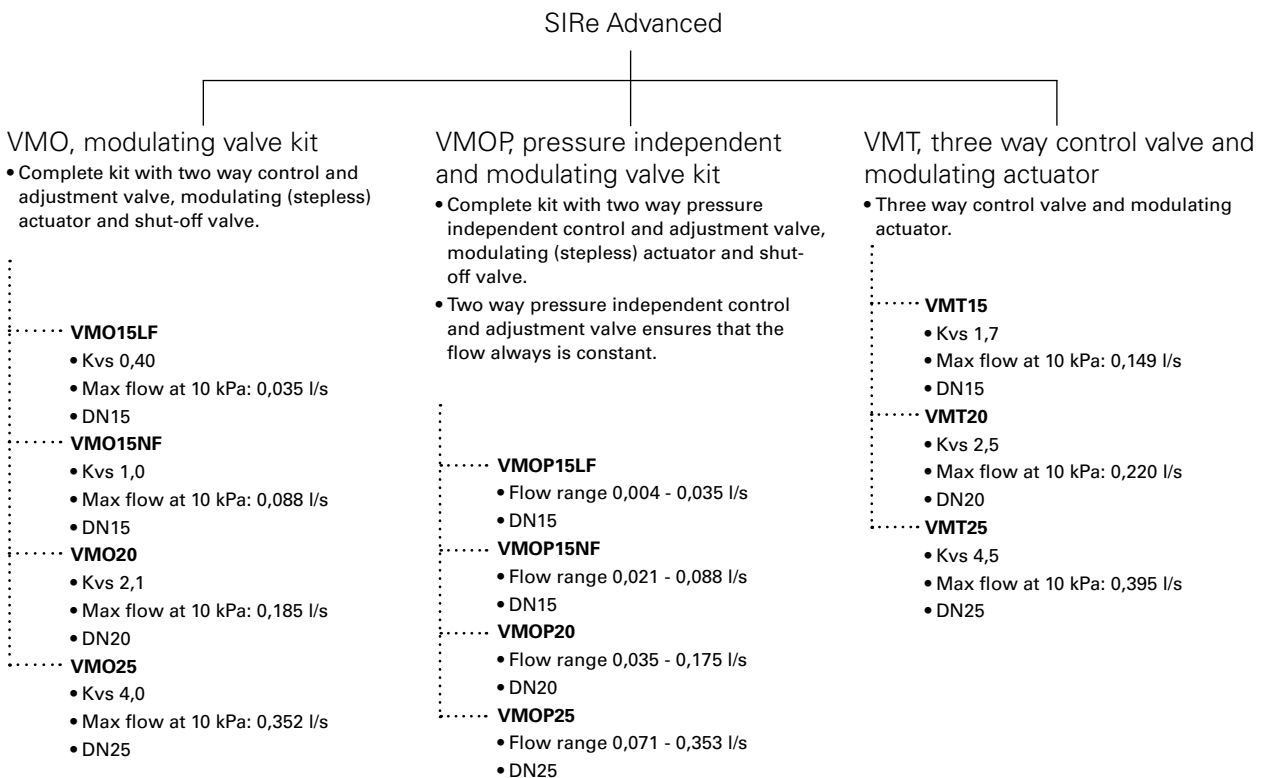
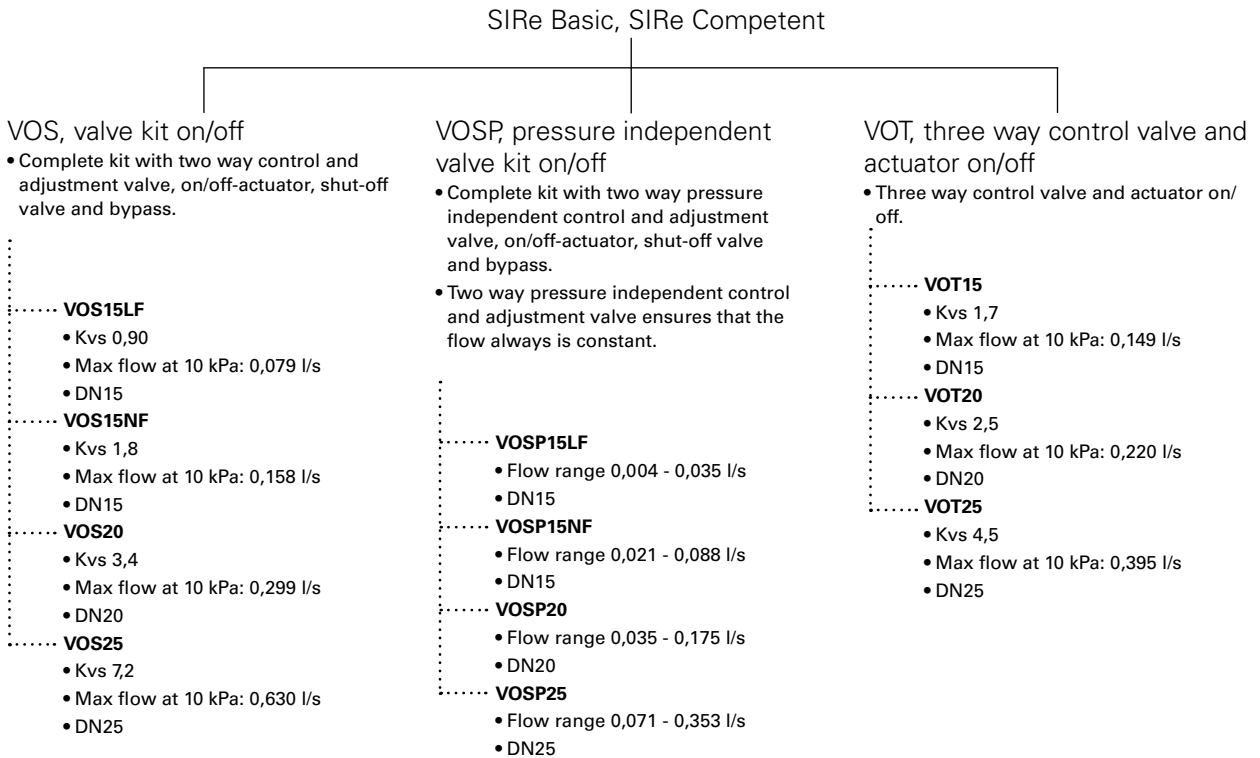

PA2500

Output charts water

			Supply water temperature:110 °C Room temperature: +18 °C Outlet air temperature: +35 °C*1				Water temperature: 110/80 °C Room temperature: +18 °C			
Type	Fan position	Airflow [m³/h]	Output [kW]	Return water temp. [°C]	Water flow [l/s]	Pressure drop [kPa]	Output *2 [kW]	Outlet air temp. [°C]	Water flow [l/s]	Pressure drop [kPa]
PA2510W	max	1300	7,4	47	0,03	0,3	13,3	48,1	0,11	3,3
	min	900	5,3	46	0,02	0,2	10,6	52,8	0,09	2,2
PA2515W	max	2100	12,5	39	0,04	0,9	24,4	52,2	0,20	13,3
	min	1250	7,4	34	0,02	0,3	17,6	59,4	0,15	7,4
PA2520W	max	2600	15,0	36	0,05	1,5	30,1	52,0	0,25	23,6
	min	1800	10,2	32	0,03	0,7	23,9	57,0	0,20	15,6

			Supply water temperature:90 °C Room temperature: +18 °C Outlet air temperature: +35 °C*1				Water temperature: 90/70 °C Room temperature: +18 °C			
Type	Fan position	Airflow [m³/h]	Output [kW]	Return water temp. [°C]	Water flow [l/s]	Pressure drop [kPa]	Output *2 [kW]	Outlet air temp. [°C]	Water flow [l/s]	Pressure drop [kPa]
PA2510W	max	1300	7,4	50	0,04	0,7	10,8	42,5	0,13	4,8
	min	900	5,2	46	0,03	0,4	8,7	46,3	0,11	3,2
PA2515W	max	2100	12,5	43	0,07	1,9	19,8	45,8	0,24	19,6
	min	1250	7,2	36	0,03	0,6	14,3	51,5	0,18	10,8
PA2520W	max	2600	15,1	41	0,08	3,1	24,4	45,6	0,30	34,6
	min	1800	10,6	36	0,05	1,5	19,3	49,6	0,24	22,8

			Supply water temperature:80 °C Room temperature: +18 °C Outlet air temperature: +35 °C*1				Water temperature: 80/60 °C Room temperature: +18 °C			
Type	Fan position	Airflow [m³/h]	Output [kW]	Return water temp. [°C]	Water flow [l/s]	Pressure drop [kPa]	Output *2 [kW]	Outlet air temp. [°C]	Water flow [l/s]	Pressure drop [kPa]
PA2510W	max	1300	7,4	52,0	0,07	1,4	8,8	38,0	0,11	3,4
	min	900	5,2	47,0	0,04	0,6	7,0	41,0	0,09	2,3
PA2515W	max	2100	12,0	44,0	0,08	3,0	16,3	40,8	0,20	14,1
	min	1250	7,3	38,0	0,04	1,0	11,7	45,6	0,14	7,8
PA2520W	max	2600	15,2	44,0	0,10	5,5	20,1	40,8	0,25	25,0
	min	1800	10,4	38,0	0,06	2,2	16,0	44,1	0,20	16,5

			Supply water temperature: 60 °C Room temperature: +18 °C Outlet air temperature: +33 °C				Water temperature: 60/40 °C Room temperature: +18 °C			
Type	Fan position	Airflow [m³/h]	Output [kW]	Return water temp. [°C]	Water flow [l/s]	Pressure drop [kPa]	Output *2 [kW]	Outlet air temp. [°C]	Water flow [l/s]	Pressure drop [kPa]
PA2510W	max	1300	6,4	50	0,16	7,1	4,7	28,6	0,06	1,2
	min	900	4,5	45	0,07	1,8	3,7	30,0	0,05	0,8
PA2515W	max	2100	10,5	45	0,17	11,3	9,2	30,8	0,11	5,4
	min	1250	6,6	40	0,08	3,0	6,6	33,5	0,08	3,0
PA2520W	max	2600	13,1	45	0,21	20,3	11,5	31,0	0,14	9,8
	min	1800	9,1	40	0,11	6,5	9,1	32,9	0,11	6,5

*1) Recommended outlet air temperature for good comfort and optimized output.

*2) Nominal output at given supply and return water temperature.

See www.frico.se for additional calculations.

Wiring diagrams

Internal wiring diagram

Unit with electrical heating

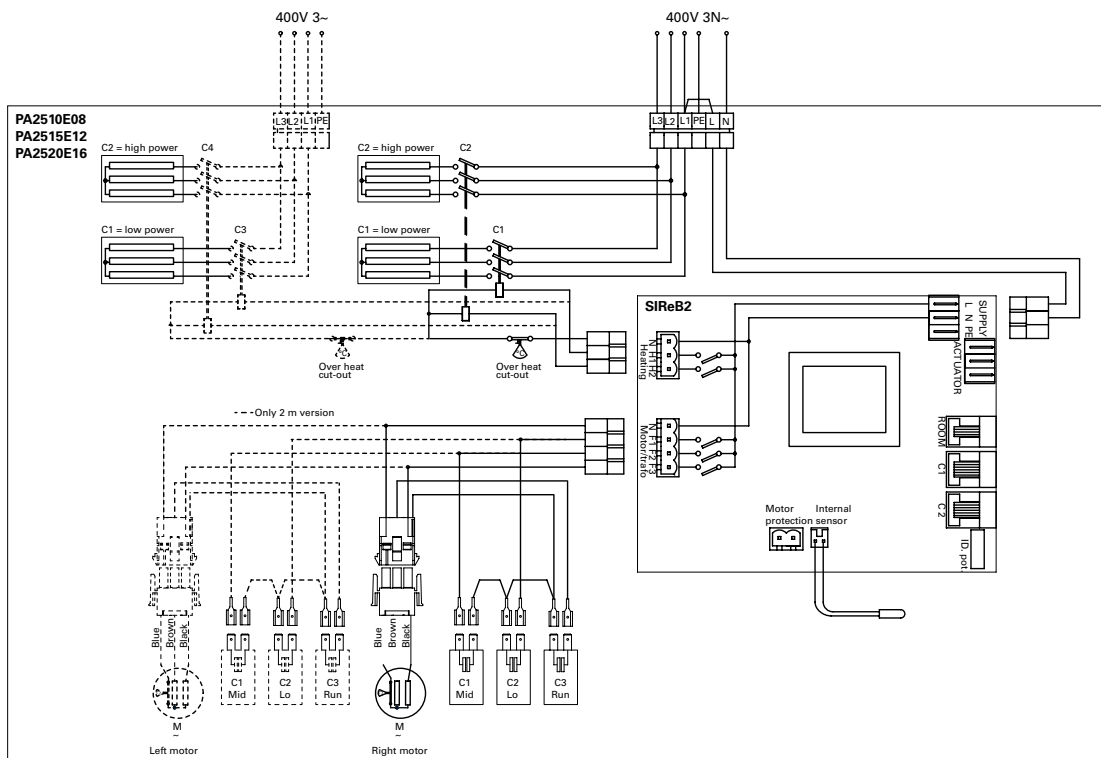
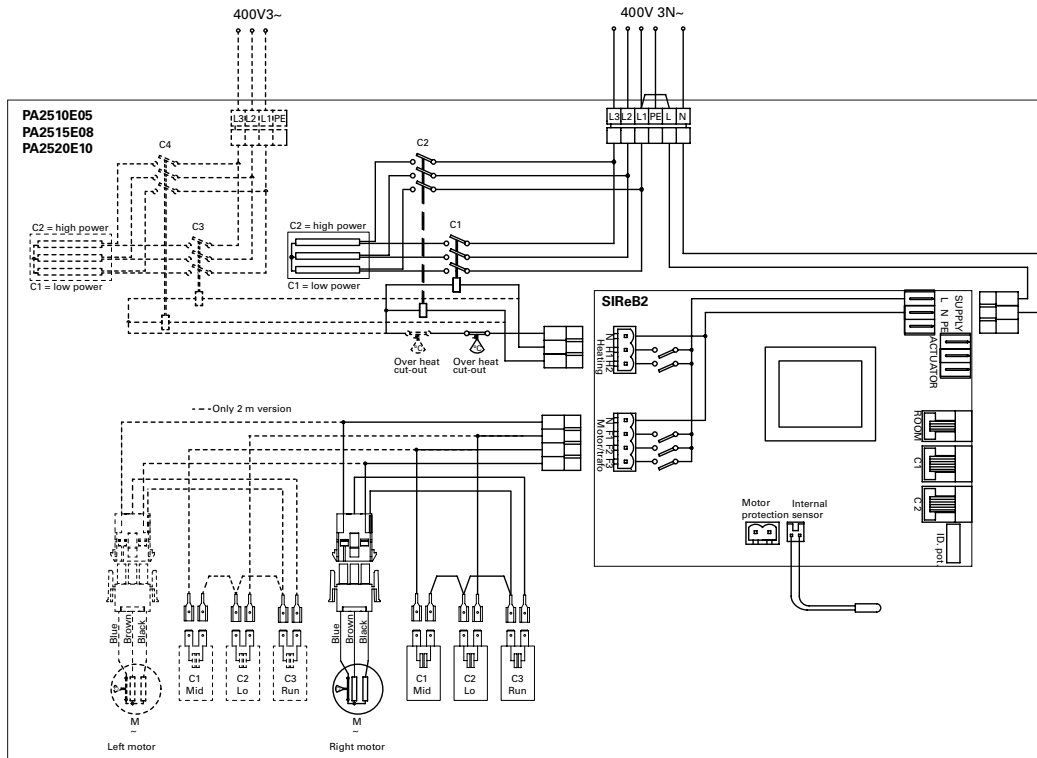

PA2500

Wiring diagrams

Internal wiring diagram

Unit with water heating

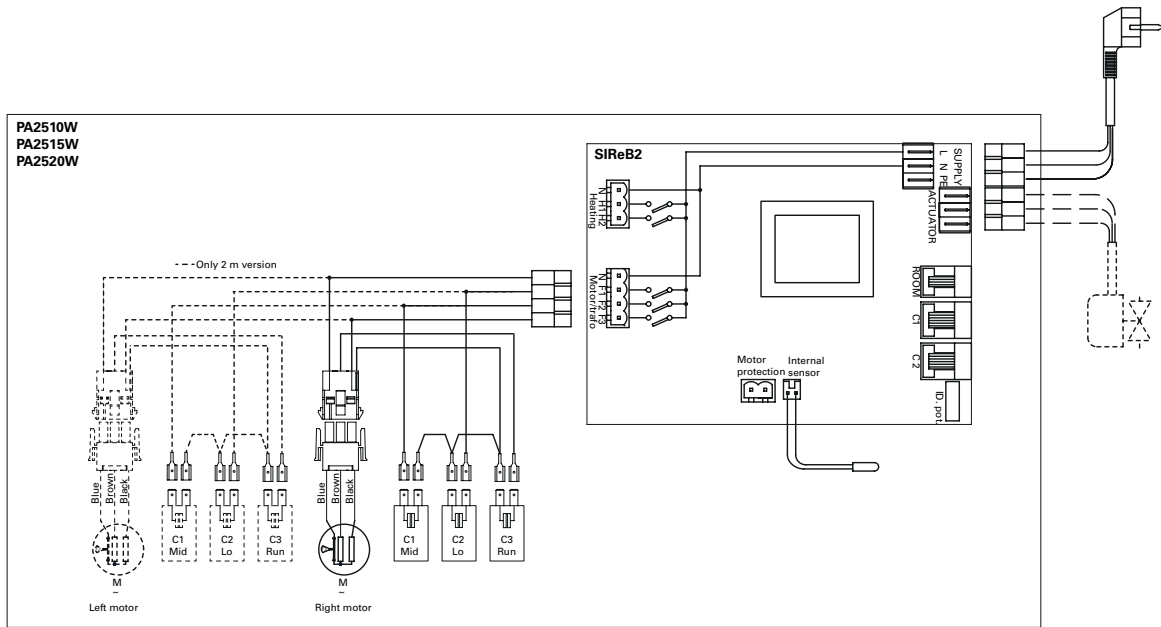

Wiring diagrams

PAMLK, motor alarm board

All units

