



## PA2200C

Stylish air curtain for entrances, with remote and integrated control

- Recommended installation height 2,2 m\*
- Horizontal mounting
- Lengths: 1, 1,5 and 2 m
- ✪ Ambient, no heat
- ⚡ Electrical heat: 3–16 kW
- 💧 Water heat



Optimized airflow with Thermozone technology.

### Application

The PA2200C is a compact air curtain, suitable for most small entrances. The air curtain has an integrated control system and can also be remotely controlled which makes it very easy to use.

PA2200C creates a temperature dividing air barrier that effectively prevents cold draughts and gives excellent heating comfort inside the door.

### Design

With its timeless design PA2200C is suitable for all entrances. The air curtain has a control panel discretely integrated in the end, which makes cable routing unnecessary. The front can be finished in any colour to perfectly match the environment.

### Air velocity profile

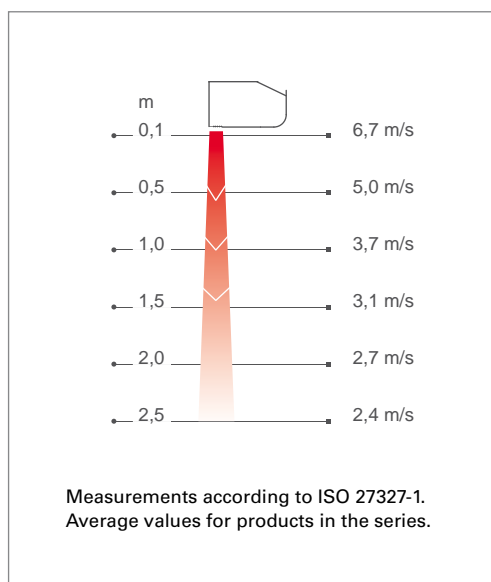

### Product specifications

- Remote control and integrated regulation.
- 3 fan steps and 2 electrical heating steps.
- Units with 3 kW are equipped with 1,5 m cable and plug.
- Wall brackets included.
- The front is easy to remove, which facilitates installation and allows easy maintenance.
- Corrosion proof housing made of hot zinc-plate and powder enamelled steel panels. Colour front: white, RAL 9016, NCS S 0500-N. Colour grille, rear section, ends and brackets: grey, RAL 7046.

## Technical specifications

### 🌀 Ambient, no heat - PA2200C A

Type	Output [kW]	Airflow [m³/h]	Sound level*1 [dB(A)]	Voltage motor [V]	Amperage motor [A]	Length [mm]	Weight [kg]
PA2210CA	0	900/1200	42/51	230V~	0,45	1050	16
PA2215CA	0	1150/1800	40/52	230V~	0,5	1560	24
PA2220CA	0	1800/2400	43/53	230V~	0,9	2050	32

### ⚡ Electrical heat - PA2200C E

Type	Output step [kW]	Airflow [m³/h]	$\Delta t^{*2}$ [°C]	Sound level*1 [dB(A)]	Voltage motor [V]	Amperage motor [A]	Voltage [V] Amperage [A] (heat)	Length [mm]	Weight [kg]
PA2210CE03	2/3	900/1200	10/7,5	42/51	230V~	0,45	230V~/13	1050	17
PA2210CE05	2,5/5	900/1200	17/12,5	42/51	230V~	0,45	400V3~/7,2	1050	17
PA2210CE08	5/8	900/1200	27/20	42/51	230V~	0,45	400V3~/11,5	1050	18
PA2215CE08	4/8	1150/1800	21/13	40/52	230V~	0,5	400V3~/11,5	1560	26
PA2215CE12	8/12	1150/1800	31/20	40/52	230V~	0,5	400V3~/17,3	1560	28
PA2220CE10	5/10	1800/2400	17/12,5	43/53	230V~	0,9	400V3~/14,4	2050	34
PA2220CE16	8/16	1800/2400	27/20	43/53	230V~	0,9	400V3~/23,1	2050	36

### 💧 Water heat - PA2200C W

Type	Output*3 [kW]	Airflow [m³/h]	$\Delta t^{*2,3}$ [°C]	Water volume [l]	Sound level*1 [dB(A)]	Voltage motor [V]	Amperage motor [A]	Length [mm]	Weight [kg]
PA2210CW	6,9	700/1200	21/17	0,38	39/52	230V~	0,4	1050	17
PA2215CW	11,1	1000/1750	22/18	0,81	37/53	230V~	0,5	1560	26
PA2220CW	14,4	1400/2400	22/18	0,74	43/53	230V~	0,8	2050	35

\*1) Conditions: Distance to the unit 5 metres. Directional factor: 2. Equivalent absorption area: 200 m². At lowest/highest airflow.

\*2)  $\Delta t$  = temperature rise of passing air at maximum heat output and lowest/highest airflow.

\*3) Applicable at water temperature 80/60 °C, air temperature, in +18 °C.

Protection class for units with electrical heating: IP20.

Protection class for units without heating and units with water heating: IP21.

CE compliant.

## Controls

### ⚡ Unit with electrical heating

#### 💧 Unit with water heating



- Remote control.
- Integrated control panel on end of unit
  - 3 fan steps, 2 electrical heating steps (electrical), heating on /off (water).
- Manual regulation of the fan.
- Automatic heating control.

### 🌀 Unit without heating



- Remote control.
- Integrated control panel on end of unit
  - 3 fan steps.
- Manual regulation of the fan.

# PA2200C

## Dimensions

All models

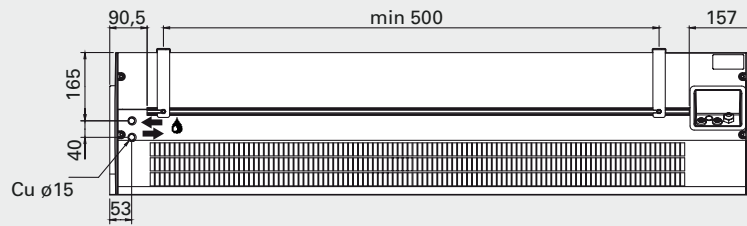
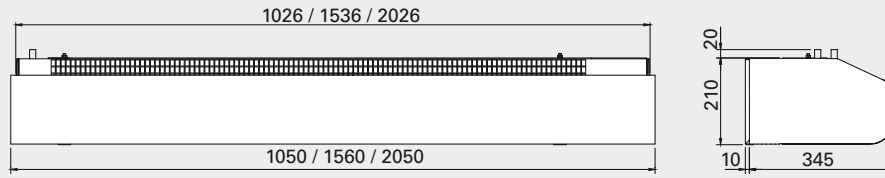

2 metre units

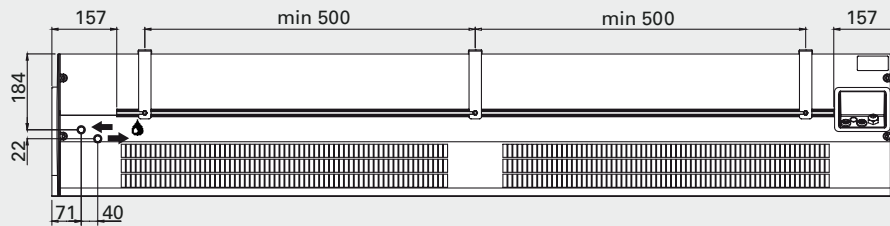

## Mounting and connection

### Mounting

The air curtain is installed horizontally with the supply air grille facing downwards as close to the door as possible.

Different installation options are available; brackets for wall mounting (included in delivery) and hanging brackets or threaded bars for ceiling mounting.

Minimum distance from outlet to floor for electrically heated units is 1800 mm.

### Connection

#### *Unit without heating*

Connected via the built-in control board with 1,5 m cord and plug.

#### *Unit with electrical heating*

The electrical connection is made on the top of the unit. The 3 kW unit is connected via the integrated control card using a 1,5 m cable and plug. Other units are intended for permanent installation. Control (230V~) and power supply for heat (400V3~) should be connected to a terminal block in the terminal box. 2-metre units require dual power supplies.

#### *Unit with water heating*

Connected via the built-in control board with 1,5 m cord and plug.

The water coil is connected on the upper side of the unit with  $\varnothing 15$  mm smooth copper pipe with a suitable coupling or soldering.

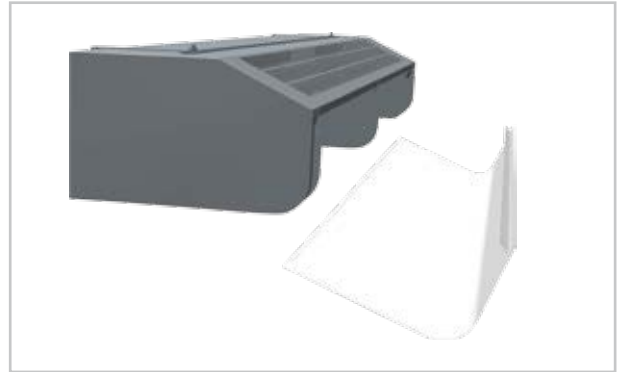

The front is easy to remove, which facilitates installation and allows easy maintenance.

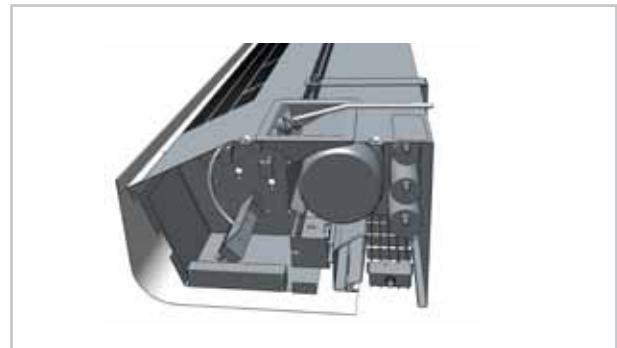

Thanks to a recess on the upper side of units with electrical heating, the wiring to and inside the unit is greatly simplified.

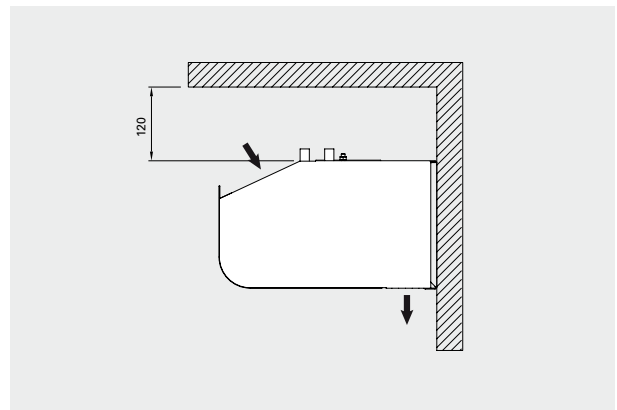

Minimum distances



Wall brackets included.

# PA2200C

## Accessories

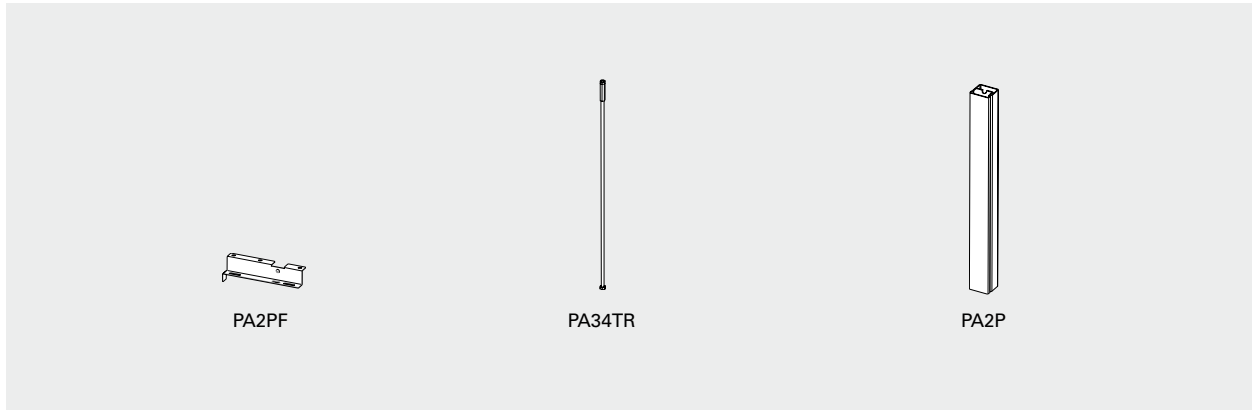

**PA2PF, ceiling mounting brackets**  
Mountings for installing the unit in the ceiling using hanging brackets or threaded bars (not included).

**PA34TR, threaded bars**  
Threaded bars for installing unit on to a ceiling. Length 1 m. Used together with ceiling mounting brackets PA2PF.

**PA2P, hanging brackets**  
Hanging brackets for installing the unit suspended from the ceiling. Length 1 m. The hanging brackets are covered by a white plastic trim to cover the cables. The brackets may be cut to shorter length, if required. Used together with ceiling mounting brackets PA2PF.

Type	Description	Quantity included	Length
<b>PA2PF15</b>	Ceiling mounting brackets for 1 and 1,5 metre units	4 pcs	
<b>PA2PF20</b>	Ceiling mounting brackets for 2 metre units	6 pcs	
<b>PA34TR15</b>	Threaded bars for 1 and 1,5 metre units	4 pcs	1 m
<b>PA34TR20</b>	Threaded bars for 2 metre units	6 pcs	1 m
<b>PA2P15</b>	Hanging brackets for 1 and 1,5 metre units	2 pcs	1 m
<b>PA2P20</b>	Hanging brackets for 2 metre units	3 pcs	1 m

## Control options

The control system is integrated in the air curtain. The air curtain has a control panel discretely integrated in the gable end and can be controlled by a separate remote control. The air speed is set manually. The heat is controlled automatically.

Door switch control PA2DR is available as an accessory for a door switch function. Possibility of using external on/off.

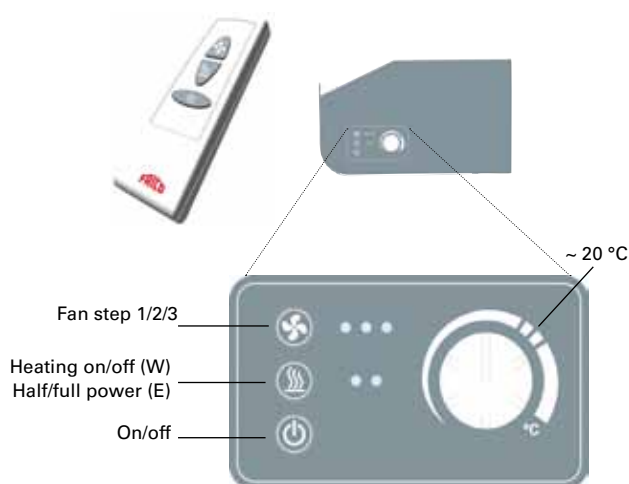

## Water control

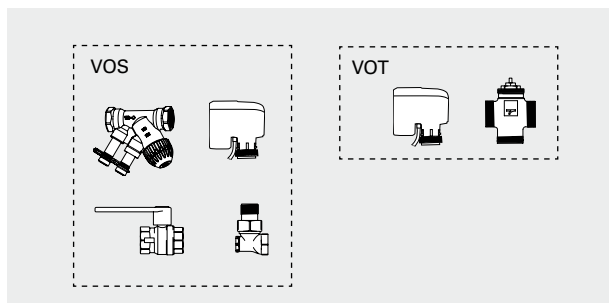

VOT, three way control valve and actuator on/off  
Used to control the water supply to water heated units. DN15/20/25.

VOS, valve kit on/off  
Two way combined control and adjustment valve with on/off actuator, shut-off valve and bypass. DN15/20/25. 230V.

Type	Description
VOT15	3-way valve and actuator on/off DN15, Kvs 1,7
VOT20	3-way valve and actuator on/off DN20, Kvs 2,5
VOT25	3-way valve and actuator on/off DN25, Kvs 4,5
VOS15LF	Valve kit on/off, low flow, DN15
VOS15NF	Valve kit on/off, DN15
VOS20	Valve kit on/off, DN20
VOS25	Valve kit on/off, DN25

## Controls

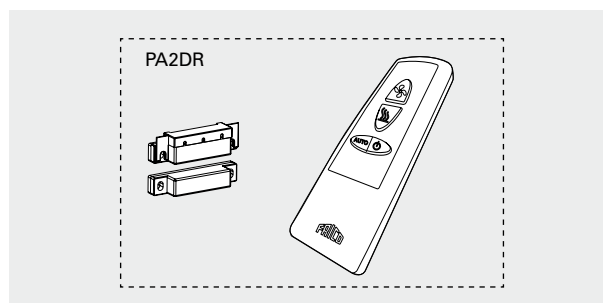

PA2DR, door switch control  
Contains a door switch for door indication and a special remote control intended to activate auto mode in the unit.

Type	Description
PA2DR	Door switch control

For further information and options, see the "Controls" section.

Output charts water

			Supply water temperature:110 °C Room temperature: +18 °C Outlet air temperature: +35 °C*1				Water temperature: 110/80 °C Room temperature: +18 °C			
Type	Fan position	Airflow [m³/h]	Output [kW]	Return water temp. [°C]	Water flow [l/s]	Pressure drop [kPa]	Output *2 [kW]	Outlet air temp. [°C]	Water flow [l/s]	Pressure drop [kPa]
PA2210CW	max	1200	6,9	53,7	0,03	1,1	10,4	43,5	0,09	6,9
	min	700	4,0	45,4	0,02	0,4	7,6	50,0	0,06	3,9
PA2215CW	max	1800	10,4	48,1	0,04	1,1	16,7	45,3	0,14	9,2
	min	1000	5,8	39,8	0,02	0,3	11,7	52,3	0,10	4,8
PA2220CW	max	2400	13,9	51,1	0,06	1,0	21,7	44,6	0,18	7,5
	min	1400	8,1	43,4	0,03	0,3	15,8	51,2	0,13	4,2

			Supply water temperature:90 °C Room temperature: +18 °C Outlet air temperature: +35 °C*1				Water temperature: 90/70 °C Room temperature: +18 °C			
Type	Fan position	Airflow [m³/h]	Output [kW]	Return water temp. [°C]	Water flow [l/s]	Pressure drop [kPa]	Output *2 [kW]	Outlet air temp. [°C]	Water flow [l/s]	Pressure drop [kPa]
PA2210CW	max	1200	6,9	57,8	0,05	3,1	8,5	38,8	0,10	10,2
	min	700	4,0	48,1	0,02	0,8	6,2	44,1	0,08	5,8
PA2215CW	max	1800	10,4	53,1	0,07	2,9	13,6	40,2	0,17	13,5
	min	1000	5,8	43,3	0,03	0,7	9,5	45,9	0,12	7,0
PA2220CW	max	2400	13,9	55,4	0,10	2,7	17,7	39,7	0,22	11,1
	min	1400	8,1	46,2	0,05	0,7	12,8	45,0	0,16	6,3

			Supply water temperature:80 °C Room temperature: +18 °C Outlet air temperature: +35 °C*1				Water temperature: 80/60 °C Room temperature: +18 °C			
Type	Fan position	Airflow [m³/h]	Output [kW]	Return water temp. [°C]	Water flow [l/s]	Pressure drop [kPa]	Output *2 [kW]	Outlet air temp. [°C]	Water flow [l/s]	Pressure drop [kPa]
PA2210CW	max	1200	6,9	60,2	0,09	7,3	6,9	35,0	0,08	7,2
	min	700	4,0	49,7	0,03	1,4	5,0	39,2	0,06	4,1
PA2215CW	max	1800	10,4	56,1	0,11	6,2	11,1	36,2	0,14	9,6
	min	1000	5,8	45,5	0,04	1,2	7,8	40,8	0,10	5,1
PA2220CW	max	2400	13,9	57,9	0,14	6,2	14,4	35,7	0,18	7,9
	min	1400	8,1	47,9	0,06	1,2	10,5	40,0	0,13	4,5

			Supply water temperature: 60 °C Room temperature: +18 °C Outlet air temperature: +32 °C				Water temperature: 60/40 °C Room temperature: +18 °C			
Type	Fan position	Airflow [m³/h]	Output [kW]	Return water temp. [°C]	Water flow [l/s]	Pressure drop [kPa]	Output *2 [kW]	Outlet air temp. [°C]	Water flow [l/s]	Pressure drop [kPa]
PA2210CW	max	1200	5,7	55,0	0,28	64,4	3,7	27,0	0,05	2,5
	min	700	3,3	46,3	0,06	4,0	2,7	29,3	0,03	1,4
PA2215CW	max	1800	8,6	52,5	0,28	36,5	6,1	28,0	0,07	3,6
	min	1000	4,8	43,3	0,07	3,1	4,3	30,6	0,05	1,9
PA2220CW	max	2400	11,4	53,4	0,42	39,7	7,8	27,5	0,09	2,8
	min	1400	6,7	44,9	0,11	3,5	5,6	29,8	0,07	1,6

\*1) Recommended outlet air temperature for good comfort and optimized output.

\*2) Nominal output at given supply and return water temperature.

See [www.frico.se](http://www.frico.se) for additional calculations.

Wiring diagrams

Internal wiring diagram

Unit without heating

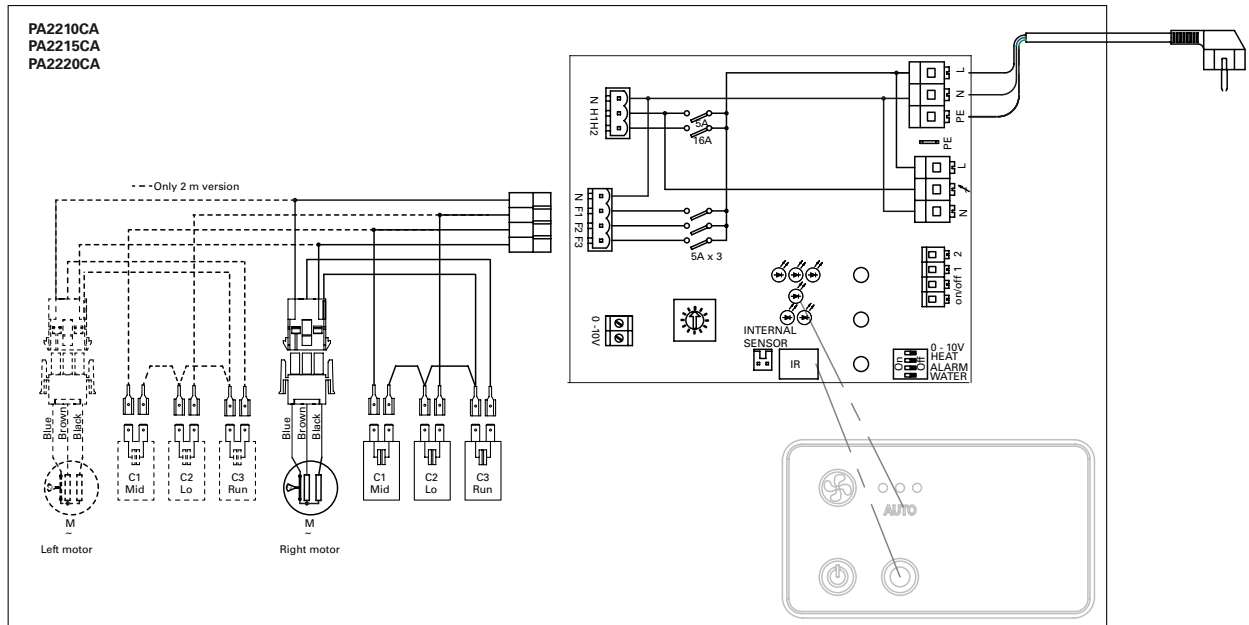

Unit with electrical heating

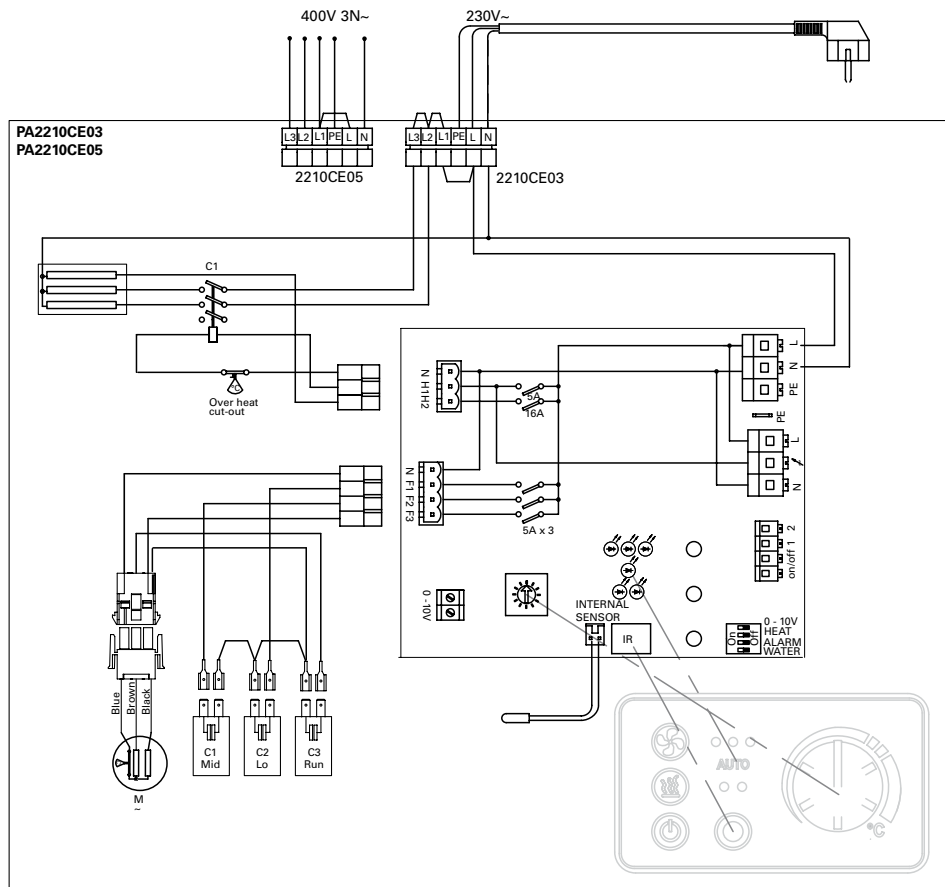



# PA2200C

## Wiring diagrams

### Internal wiring diagram

#### Unit with electrical heating

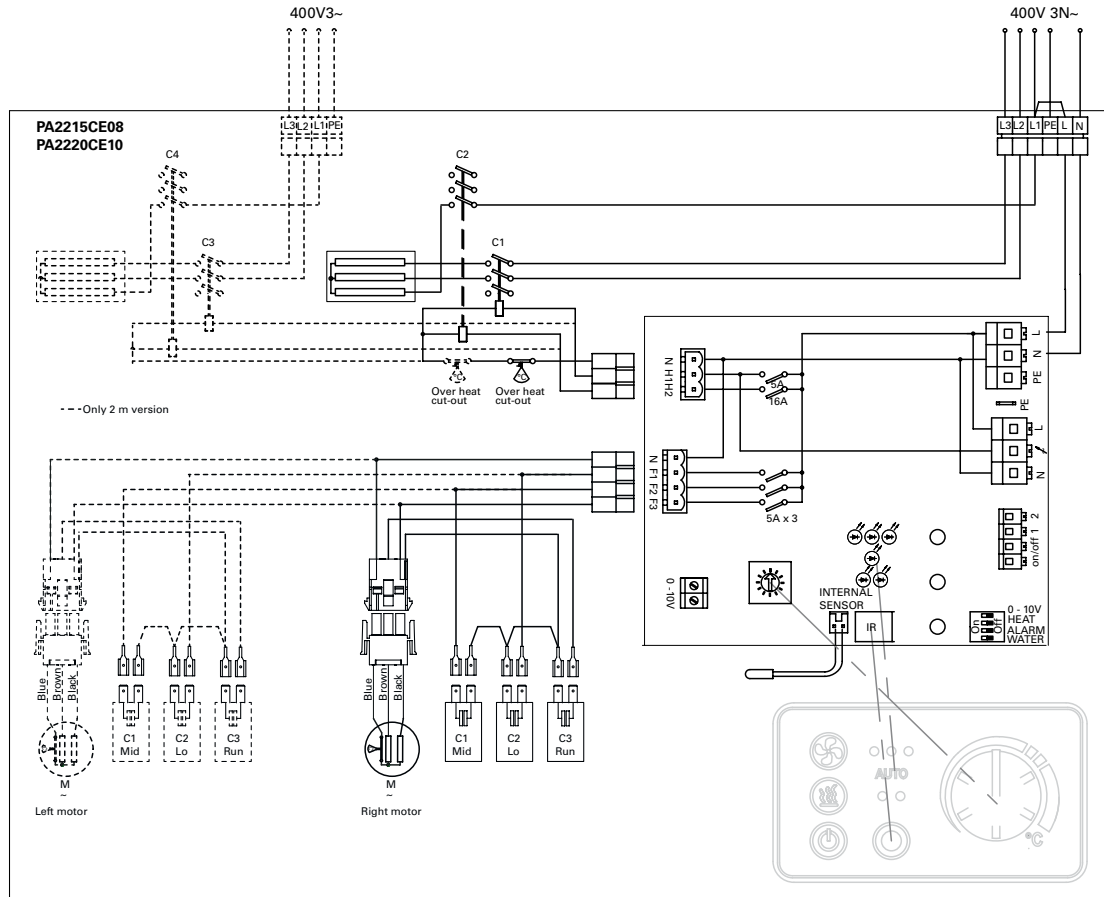

Wiring diagrams

Internal wiring diagram

Unit with electrical heating

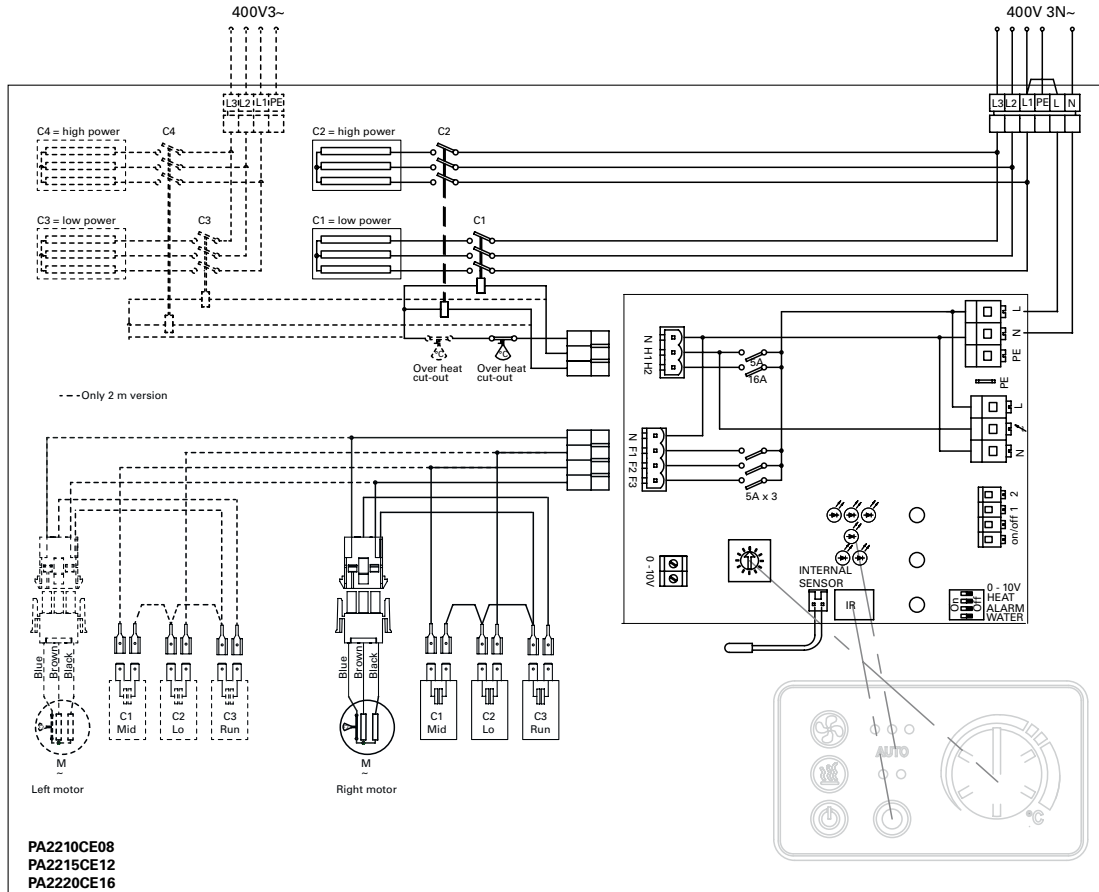

Unit with water heating

